

DESCRIPTION OF CHIP RESISTORS

- Seven (7) Available Sizes - 0402, 0603, 0805, 1206, 1210, 2010, 2512
- 1/16 Watt to 1 Watt Power Ratings
- 0.1 Ohm to 22 Meg Ohm Resistance Range
- Tight Tolerance and Low TCR Available
- Excellent Solderability
- Nickel Barrier for Leaching Control
- Paper and Plastic Tape Packaging

CONSTRUCTION & MECHANICAL DIMENSIONS

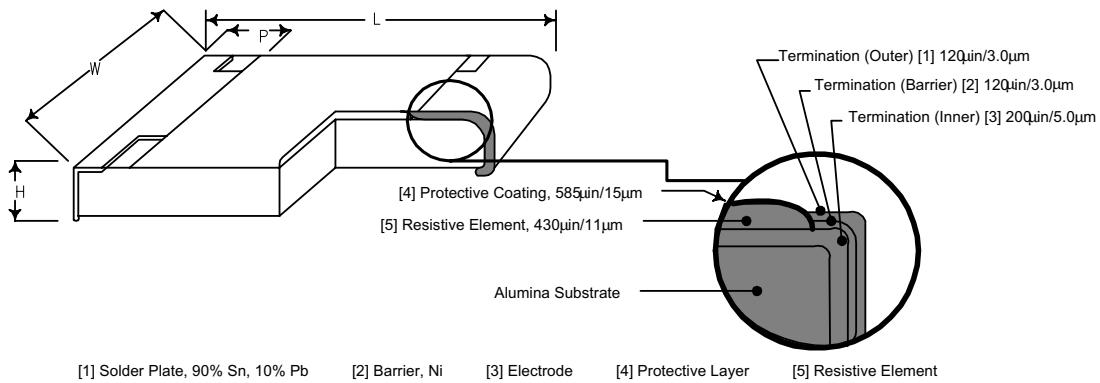

SIZE CODE (inches)	DIMENSIONS in/mm					EIA SIZE REFERENCE
	L	W	H	P TOP	P BOTTOM	
1E (0402)	0.04 ^{+0.004} / _{-0.002} 1.0 + 0.1/-0.05	0.02 ± 0.002 0.5 ± 0.05	0.014 ± 0.002 0.35 ± 0.05	0.008 ± 0.004 0.2 ± 0.1	0.001 ^{+0.002} / _{-0.004} 0.25 + 0.05/-0.1	1005
1J (0603)	0.063 ± 0.008 1.6 ± 0.2	0.031 ± 0.004 0.8 ± 0.1	0.020 ± 0.004 0.5 ± 0.1	0.012 ± 0.004 0.3 ± 0.1	0.012 ± 0.004 0.3 ± 0.1	1608
2A (0805)	0.079 ± 0.008 2.0 ± 0.2	0.049 ± 0.004 1.25 ± 0.1	0.020 ± 0.004 0.5 ± 0.1	0.016 ± 0.008 0.4 ± 0.2	0.012 ^{+0.008} / _{-0.004} 0.3 + 0.2/-0.1	2021
2B (1206)	0.126 ± 0.008 3.2 ± 0.2	0.063 ± 0.008 1.6 ± 0.2	0.024 ± 0.004 0.6 ± 0.1	0.020 ± 0.012 0.5 ± 0.3	0.016 ^{+0.008} / _{-0.004} 0.4 + 0.2/-0.1	3216
2E (1210)	0.126 ± 0.008 3.2 ± 0.2	0.102 ± 0.008 2.6 ± 0.2	0.024 ± 0.004 0.6 ± 0.1	0.020 ± 0.012 0.5 ± 0.3	0.016 ^{+0.008} / _{-0.004} 0.4 + 0.2/-0.1	3225
2H (2010)	0.197 ± 0.008 5.0 ± 0.2	0.098 ± 0.008 2.5 ± 0.2	0.024 ± 0.004 0.6 ± 0.1	0.020 ± 0.012 0.5 ± 0.3	0.016 ^{+0.008} / _{-0.004} 0.4 + 0.2/-0.1	5025
3A (2512)	0.248 ± 0.008 6.3 ± 0.2	0.122 ± 0.008 3.1 ± 0.2	0.024 ± 0.004 0.6 ± 0.1	0.020 ± 0.012 0.5 ± 0.3	0.016 ^{+0.008} / _{-0.004} 0.4 + 0.2/-0.1	6332

FLAT CHIP RESISTOR - PRECISION

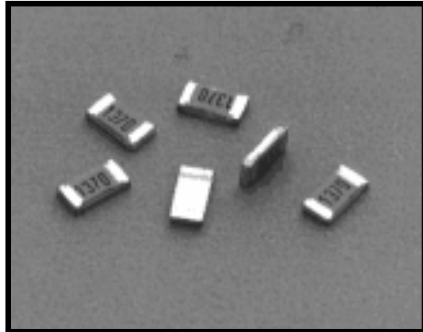

- RuO₂ Thick Film Resistor Element
- Anti-Leaching Nickel Barrier Terminations
- 90/10 Solder Plated Terminations, Standard
- Also Available with Epoxy Bondable (Palladium Silver) Terminations in 0805 and 1206 sizes.
- Meets or Exceeds EIA 575, EIAJ RC 2690A, EIA PDP - 100, MIL - R - 55342F, UL94V-0
- 4 Digit, Black Marking on Blue Protective Coat. (Only E-24 Values are marked on 0603, 3 digit) No Marking on 1E (0402) size.

STANDARD APPLICATIONS

PART DESIGNATION *	POWER RATING @70°C	TCR (ppm/°C) MAX	RESISTANCE RANGE (E-96)*** (D±0.5%)	RESISTANCE RANGE (E-96)*** (F±1%)	ABSOLUTE MAXIMUM WORKING VOLTAGE	ABSOLUTE MAXIMUM OVERLOAD VOLTAGE	OPERATING TEMPERATURE RANGE
RK73H1E (0402)	63mW	±200		10Ω - 1MΩ	50V	100V	-55°C to +125°C
RK73H1J ** (0603)	100mW	±100	10Ω - 976KΩ	10Ω - 1MΩ	50V	100V	-55°C to +175°C
RK73H2A (0805)	125mW	±100	10Ω - 976KΩ	10Ω - 1MΩ	150V	300V	
		±400		1.0Ω - 9.76Ω 1.02MΩ - 10MΩ			
RK73H2B (1206)	250mW	±100	10Ω - 976KΩ	10Ω - 1MΩ	200V	400V	
		±200		1.02MΩ - 5.6MΩ			
		±400		1.0Ω - 9.76Ω 5.62MΩ - 10MΩ			
RK73H2E (1210)	330mW	±100	10Ω - 976KΩ	10Ω - 1MΩ	200V	400V	
		±200		1.02MΩ - 5.6MΩ			
		±400		1.0Ω - 9.76Ω 5.62MΩ - 10MΩ			
RK73H2H (2010)	750mW	±100	10Ω - 976KΩ	10Ω - 1MΩ	200V	400V	
		±200		1.02MΩ - 5.6MΩ			
		±400		1.0Ω - 9.76Ω 5.62MΩ - 10MΩ			
RK73H3A (2512)	1000mW	±100	10Ω - 976KΩ	10Ω - 1MΩ	200V	400V	
		±200		1.02MΩ - 5.6MΩ			
		±400		1.0Ω - 9.76Ω 5.62MΩ - 10MΩ			

*Parenthesis indicate EIA package size codes
 **The RK73H1J (0603) is available in E24 series (marked) & E96 series (unmarked)

ORDERING & SPECIFYING INFORMATION*

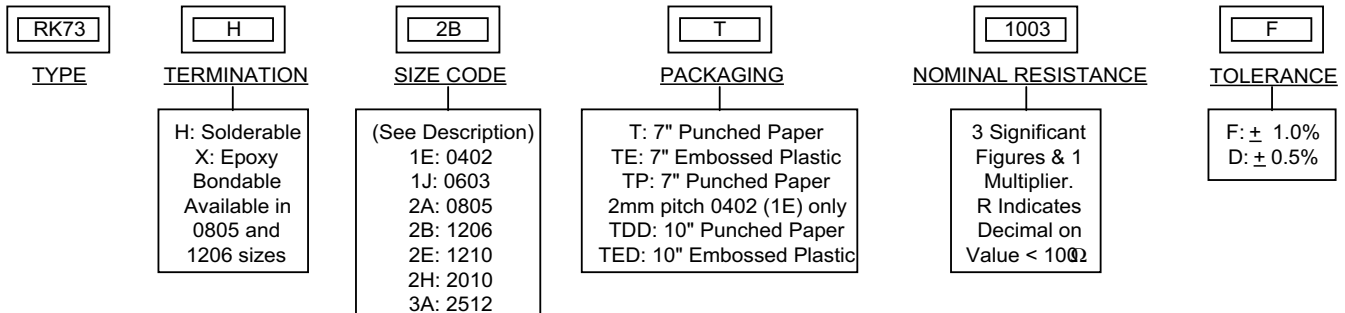

*Please Note: KSE's Part Numbers Do Not Contain any Spaces or Hyphens.

ENVIRONMENTAL APPLICATIONS

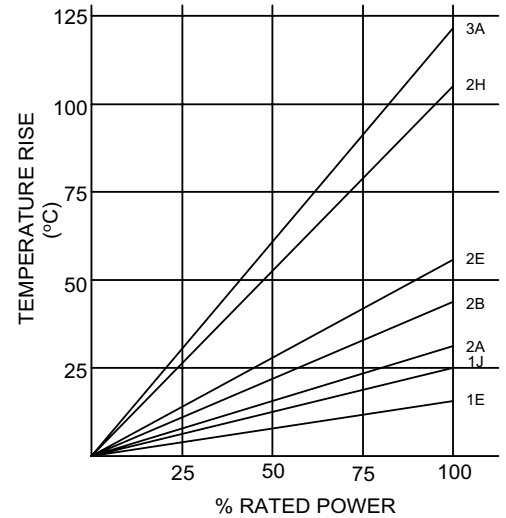
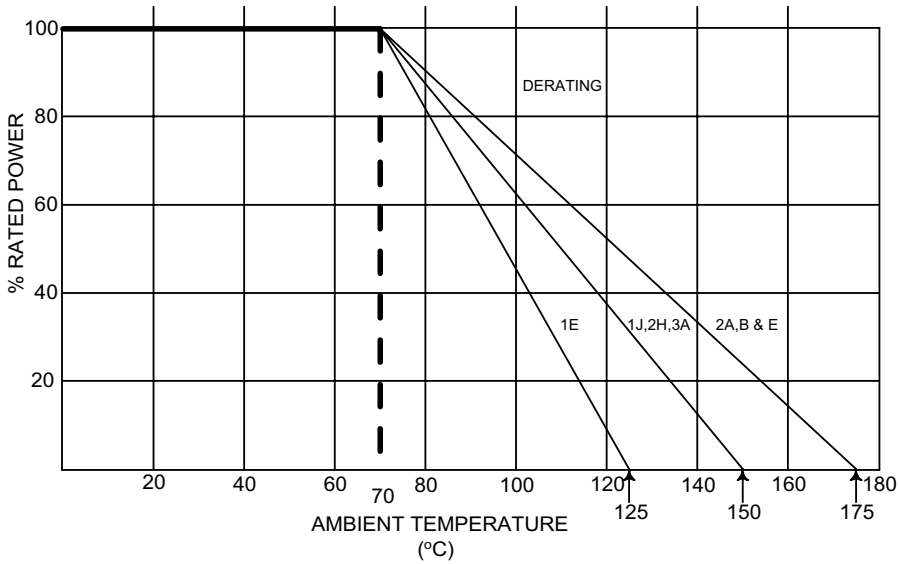

PARAMETER	MAXIMUM ΔR	TEST METHOD
Thermal Shock	± 0.2%	MIL-STD-202, Method 107 -55°C ~ +125°C, 5 cycles
Low Temperature Operation	± 0.2%	MIL - R - 55342π 4.7.4 1 Hour @ -55°C followed by 45 minutes of RCWV**
High Temperature Exposure	± 0.5%	MIL - R - 55342π 4.7.6 100 Hours @ 125°C
Short Time Overload	± 2.0%	MIL - R - 55342π 4.7.5 2.5 X RCWV for 5 seconds
Resistance to Solder Heat	± 0.2%	MIL - R - 55342π 4.7.7 260°C for 10 seconds
Terminal Strength-Push	± 0.75%	1.2 Kg for 1 minute
Terminal Strength-Bend	± 0.5%	5mm Deflection in either direction for 10 seconds
Moisture Resistance	± 0.5%	MIL - STD - 202, Method 106 10 cycles for 240 hours
Life	± 0.75%	MIL - STD - 202, Method 108 7°C, 1000 hours @ RCWV**, 1.5 Hr on, 0.5 Hr off.
Pulse	± 1.5%	2.5 X RCWV**, Not exceeding maximum overload voltage 1 second ON, 25 seconds OFF 10,000 cycles
Temperature Cycling	± 0.75%	30 Minutes at -55°C; 15 Minutes at +25°C, 30 Minutes at + 125°C, 15 Minutes at +25°C, 5 Cycles
MINIMUM		
Terminal Adhesion	15 Grams	Axial Pull, One Terminal at a Time
Dielectric Withstanding Voltage		MIL - STD - 202, Method 301
	1E 100V	
	1J 100V	
	2A 400V	
	2B 400V	
	2E 400V	
	2H 400V	
	3A 400V	
Insulation Resistance	10,000 Meg Ohm	

**RCWV = Rated Continuous Working Voltage

FLAT CHIP RESISTOR- ZERO OHM JUMPER

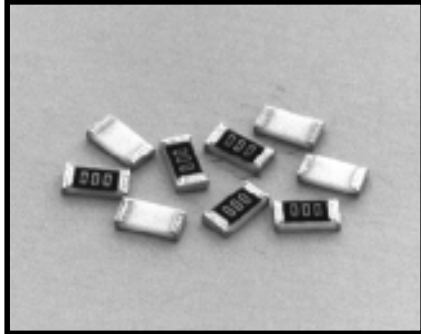

- Silver Element
- Anti-Leaching Nickel Barrier Terminations
- 90/10 Solder Plated Terminations, Standard
- UL94V-0 Coatings
- White 000 Markings on Black Protective Coat: No Marking on 1E (0402) size.
- 1J (0603) has White 0 Marking
- Also available in 100% Tin Terminations (No lead).

STANDARD APPLICATIONS

PART DESIGNATION	MAXIMUM CURRENT (Amps) @ 70°C	MAXIMUM RESISTANCE
RM73Z 1E	1.0	50mΩ
RM73Z 1J	2.0 Max. Surge for < 1 sec.	
RM73Z 2A	1.5 5.0 Max. Surge for < 1 sec.	
RM73Z 2B RM73Z 2E RM73Z 2H RM73Z 3A	2.0 10 Max. Surge for < 1 sec.	

ORDERING & SPECIFYING INFORMATION*

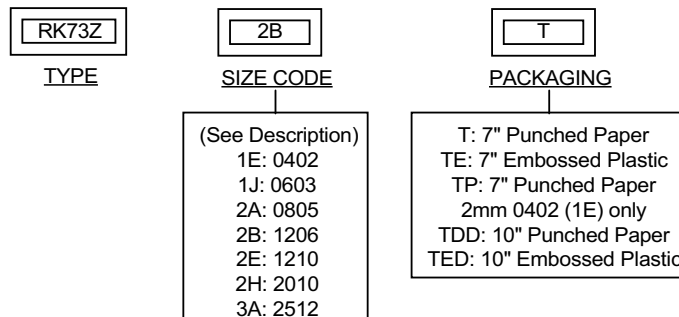

*Please Note: KSE's Part Numbers Do Not Contain any Spaces or Hyphens.

CARRIER TAPE

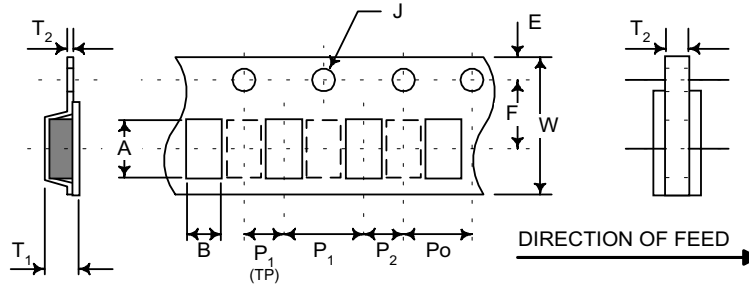

NOTES: Dotted lines are applicable for 1E, 1J, and 2B sizes on 1000 piece reels.

PACKAGING SPECIFICATIONS

DIMENSIONS (mm)

PACKAGING	SIZE CODE	A	B	W	E	F	T1	T2	P0	P1	P2	J
(TP) 7" PAPER TAPE (2mm PITCH)	1E (0402)	1.15±0.1	0.65±0.1	8.0±0.2	1.75±0.1	3.5±0.05	—	0.45±0.1	4.0±0.1	2.0±0.05	2.0±0.05	1.5 ^{+0.1} ₀
(T) 7" PAPER TAPE	1J (0603)	1.9±0.1	1.1±0.1	"	"	"	—	0.60±0.1	"	4.0±0.1	"	"
	2A (0805)	2.4±0.1	1.65±0.1	"	"	"	—	0.75±0.1	"	"	"	"
	2B (1206)	3.5±0.1	1.9±0.1	"	"	"	—	"	"	"	"	"
	2E (1210)	3.5±0.1	2.8±0.1	"	"	"	—	"	"	"	"	"
(TE) 7" EMBOSSED PLASTIC	2A (0805)	2.4±0.2	1.45±0.15	"	"	"	0.85±0.1	0.25±0.1	"	"	"	"
	2B (1206)	3.5±0.1	1.9±0.2	"	"	"	1.0±0.1	"	"	"	"	"
	2E (1210)	3.6±0.15	2.9±0.15	"	"	"	"	0.2±0.1	"	"	"	"
	2H (2010)	5.4±0.2	2.9±0.2	12.0±0.1	"	5.5±0.5	0.85±0.1	"	"	"	"	"
	3A (2512)	6.9±0.2	3.6±0.2	"	"	"	"	"	"	4.0±0.1	"	"
(TDD) 10" PAPER TAPE	1J (0603)	1.9±0.1	1.1±0.1	8.0±0.2	1.75±0.1	3.5±0.05	—	0.60±0.1	"	"	"	"
	2A (0805)	2.4±0.1	1.65±0.1	"	"	"	—	0.75±0.1	"	"	"	"
	2B (1206)	3.5±0.1	1.9±0.1	"	"	"	—	"	"	"	"	"
	2E (1210)	3.5±0.1	2.8±0.1	"	"	"	—	"	"	"	"	"
(TED) 10" EMBOSSED PLASTIC	2A (0805)	2.4±0.2	1.45±0.15	"	"	"	0.85±0.1	0.25±0.1	"	"	"	"
	2B (1206)	3.5±0.1	1.9±0.2	"	"	"	1.0±0.1	"	"	"	"	"
	2E (1210)	3.6±0.15	2.9±0.15	"	"	"	"	0.2±0.1	"	"	"	"
	2H (2010)	5.4±0.2	2.9±0.2	12.0±0.1	"	5.5±0.5	0.85±0.1	"	"	"	"	"
	3A (2512)	6.9±0.2	3.6±0.2	"	"	"	"	"	"	4.0±0.1	"	"

REEL SPECIFICATIONS

SIZE CODE	DIMENSIONS (mm)								
	Z max.			X	R	S	C	D	K
	7"	10"	13"						
1E (0402)	178	255	330	80±2.0	10±1.0	1.5±.05	13±0.5	27±2.0	3.0±0.5
1J (0603)									
2A (0805)									
2B (1206)									
2E (1210)									
2H (2010)	60±2.0	14±1.0	21±2.0	2.0±0.5					
3A (2512)									

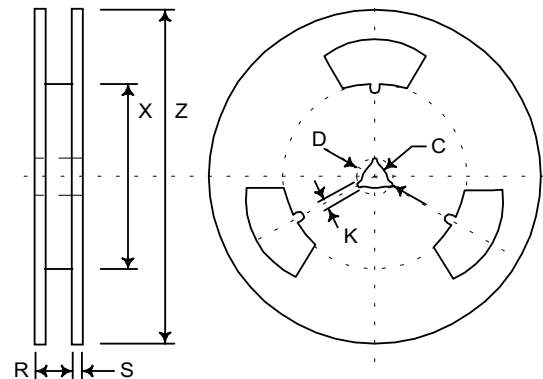

PACKAGING SPECIFICATIONS

METHOD

SIZE CODE	(T) 7" PAPER TAPE	(TE) 7" EMBOSSED PLASTIC	(TP) 7" PUNCHED PAPER	(TDD) 10" PUNCHED PAPER	(TED) 10" EMBOSSED PLASTIC	BULK
1E (0402)	—	—	10000	—	—	1000
1J (0603)	5000	—	—	10000	—	1000
2A (0805)	5000	4000	—	10000	10000	1000
2B (1206)	5000	4000	—	10000	10000	1000
2E (1210)	5000	4000	—	10000	—	1000
2H (2010)	—	4000	—	—	10000	1000
3A (2512)	—	4000	—	—	10000	1000

MARKING

KSE PART DESIGNATION	COLOR		MARKING
	BODY	MARKING	TYPE
RM73B1E (0402)	BLACK	NONE
RM73B1J (0603)	BLACK	WHITE	3 DIGITS
RK73H1J (0603)	BLUE	E-24 BLACK E-96 NONE	3 DIGITS
RM73B2A (0805) 2B (1206) 2E (1210) 2H (2010) 3A (2512)	BLACK	WHITE	3 DIGITS
RK73H2A (0805) 2B (1206) 2E (1210) 2H (2010) 3A (2512)	BLUE	BLACK	4 DIGITS
RM73Z1E (0402) RM73Z1J (0603) 2A (0805) 2B (1206) 2E (1210) 2H (2010) 3A (2512)	GREEN BLACK	NONE WHITE 000
RN73T2A (0805) 2B (1206) 2E (1210)	GREEN	RED	4 DIGITS
RN73E1J (0603)	BLACK	WHITE	3 DIGITS
RN73E2A (0805) 2B (1206) 2E (1210)	GREEN	YELLOW	4 DIGITS
RN73C1J (0603)	BLACK	WHITE	3 DIGITS
RN73C2A (0805) 2B (1206) 2E (1210)	GREEN	YELLOW	4 DIGITS
RK73N2A (0805) 2B (1206) 2E (1210) 2H (2010) 3A (2512)	BLACK	NONE	NONE
LT73 2A (0805) 2B (1206)	BRONZE	BLACK	3 DIGITS
RF73B2A (0805) 2B (1206)	BROWN	BLACK	3 DIGITS
NT73 2A (0805) 2B (1206)	PINK	BLACK	3 DIGITS
SR73 2A (0805) 2B (1206) 2E (1210) 2H (2010) 3A (2512)	INDIGO	WHITE	E-96 - 4 DIGITS E-24 - 3 DIGITS
CR73 2B (1206)	BLUE/ YELLOW	NONE	

STANDARD E-24 (5%) DECADE VALUES

1.0 1.1 1.2 1.3 1.5 1.6 1.8 2.0 2.2 2.4 2.7 3.0
3.3 3.6 3.9 4.3 4.7 5.1 5.6 6.2 6.8 7.5 8.2 9.1

STANDARD E-96 (< 1%) DECADE VALUES

100 102 105 107 110 113 115 118 121 124 127 130
133 137 140 143 147 150 154 158 162 165 169 174
178 182 187 191 196 200 205 210 215 221 226 232
237 243 249 255 261 267 274 280 287 294 301 309
316 324 332 340 348 357 365 374 383 392 402 412
422 432 442 453 464 475 487 499 511 523 536 549
562 576 590 604 619 634 649 665 681 698 715 732
750 768 787 806 825 845 866 887 909 931 953 976