

PRODUKTINFORMATION



HÄMTFAX
08-580 941 14



FAX ON DEMAND
+46 8 580 941 14



INTERNET
<http://www.elfa.se>

TEKNISK INFORMATION 020-75 80 20 ORDERTEL 020-75 80 00 ORDERFAX 020-75 80 10

TECHNICAL INFORMATION +46 8 580 941 15 ORDERPHONE +46 8 580 941 01 ORDERFAX +46 8 580 941 11

— Vi reserverar oss mot fel samt förbehåller oss rätten till ändringar utan föregående meddelande —

ELFA artikelnr.

73-117-07 TL071CP JFET op-amp
73-117-15 TL072CP/TA75072P JFET op
73-117-23 TL071IP JFET op-amp
73-117-49 TL074IN fyrdubbel JFET-op

Antal sidor: 18

73-117-56 TL074CN/TDB0074DB JFET-op
73-300-95 TL071CD op-amp SO8
73-301-03 TL072CDR op-amp SO8
73-301-11 TL074CD op-amp SO14

TL071, TL071A, TL071B, TL072 TL072A, TL072B, TL074, TL074A, TL074B LOW-NOISE JFET-INPUT OPERATIONAL AMPLIFIERS

SLOS080D – SEPTEMBER 1978 – REVISED AUGUST 1996

- Low Power Consumption
- Wide Common-Mode and Differential Voltage Ranges
- Low Input Bias and Offset Currents
- Output Short-Circuit Protection
- Low Total Harmonic Distortion
0.003% Typ
- Low Noise
 $V_n = 18 \text{ nV}/\sqrt{\text{Hz}}$ Typ at $f = 1 \text{ kHz}$
- High Input Impedance . . . JFET Input Stage
- Internal Frequency Compensation
- Latch-Up-Free Operation
- High Slew Rate . . . $13 \text{ V}/\mu\text{s}$ Typ
- Common-Mode Input Voltage Range
Includes V_{CC+}

description

The JFET-input operational amplifiers in the TL07_ series are designed as low-noise versions of the TL08_ series amplifiers with low input bias and offset currents and fast slew rate. The low harmonic distortion and low noise make the TL07_ series ideally suited for high-fidelity and audio preamplifier applications. Each amplifier features JFET inputs (for high input impedance) coupled with bipolar output stages integrated on a single monolithic chip.

The C-suffix devices are characterized for operation from 0°C to 70°C. The I-suffix devices are characterized for operation from –40°C to 85°C. The M-suffix devices are characterized for operation over the full military temperature range of –55°C to 125°C.

AVAILABLE OPTIONS

T _A	V _{IO} max AT 25°C	PACKAGE							
		SMALL OUTLINE (D)†	CHIP CARRIER (FK)	CERAMIC DIP (J)	CERAMIC DIP (JG)	PLASTIC DIP (N)	PLASTIC DIP (P)	TSSOP PACKAGE (PW)	FLAT PACKAGE (W)
0°C to 70°C	10 mV 6 mV 3 mV	TL071CD TL071ACD TL071BCD	—	—	—	—	TL071CP TL071ACP TL071BCP	TL071CPWLE — —	—
	10 mV 6 mV 3 mV	TL072CD TL072ACD TL072BCD	—	—	—	—	TL072CP TL072ACP TL072BCP	TL072CPWLE — —	—
	10 mV 6 mV 3 mV	TL074CD TL074ACD TL074BCD	—	—	—	TL074CN TL074ACN TL074BCN	—	TL074CPWLE — —	—
–40°C to 85°C	6 mV	TL071ID TL072ID TL074ID	—	—	—	— — TL074IN	TL071IP TL072IP —	—	—
–55°C to 125°C	6 mV 6 mV 9 mV	—	TL071MFK TL072MFK TL074MFK	— — TL074MJ	TL071MJG TL072MJG —	— — TL074MN	— TL072MP —	—	— — TL074MW

† The D package is available taped and reeled. Add the suffix R to the device type (e.g., TL071CDR). The PW package is only available left-ended taped and reeled (e.g., TL072CPWLE).



Please be aware that an important notice concerning availability, standard warranty, and use in critical applications of Texas Instruments semiconductor products and disclaimers thereto appears at the end of this data sheet.

PRODUCTION DATA information is current as of publication date. Products conform to specifications per the terms of Texas Instruments standard warranty. Production processing does not necessarily include testing of all parameters.



POST OFFICE BOX 655303 • DALLAS, TEXAS 75265

Copyright © 1996, Texas Instruments Incorporated

TL071, TL071A, TL071B, TL072 TL072A, TL072B, TL074, TL074A, TL074B LOW-NOISE JFET-INPUT OPERATIONAL AMPLIFIERS

SLOS080D – SEPTEMBER 1978 – REVISED AUGUST 1996

TL071, TL071A, TL071B
D, JG, P, OR PW PACKAGE
(TOP VIEW)

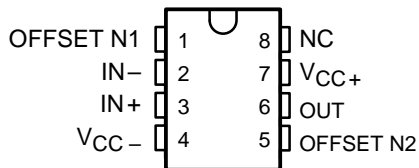

TL072, TL072A, TL072B
D, JG, P, OR PW PACKAGE
(TOP VIEW)

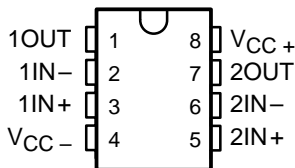

TL074, TL074A, TL074B
D, J, N, OR PW PACKAGE
TL074...W PACKAGE
(TOP VIEW)

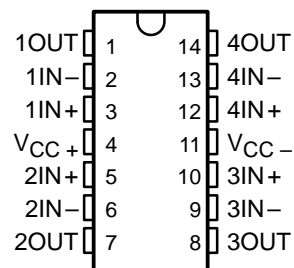

TL071
FK PACKAGE
(TOP VIEW)

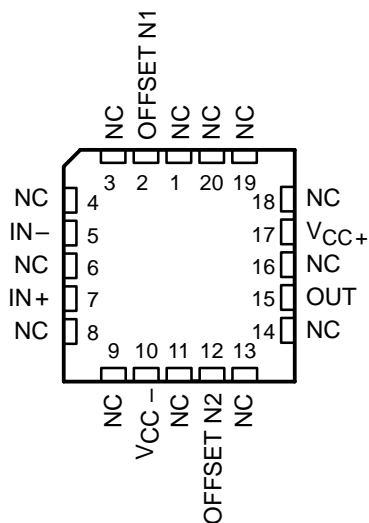

TL072
FK PACKAGE
(TOP VIEW)

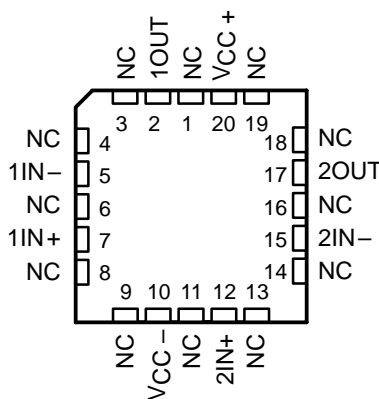

TL074
FK PACKAGE
(TOP VIEW)

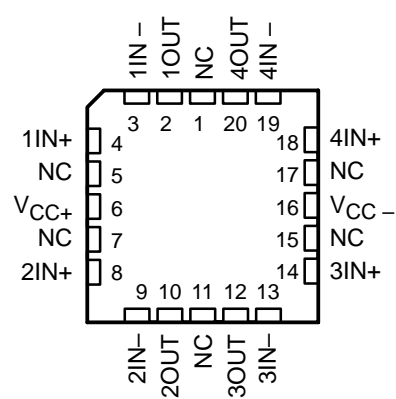

NC – No internal connection

symbols

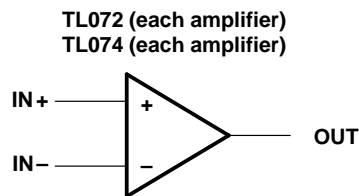
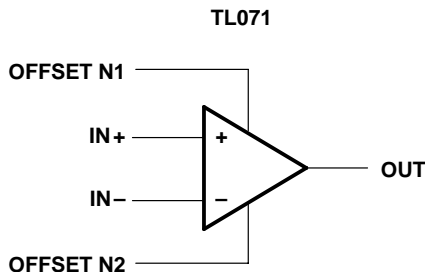

**TL071, TL071A, TL071B, TL072
TL072A, TL072B, TL074, TL074A, TL074B**
LOW-NOISE JFET-INPUT OPERATIONAL AMPLIFIERS

SLOS080D – SEPTEMBER 1978 – REVISED AUGUST 1996

schematic (each amplifier)

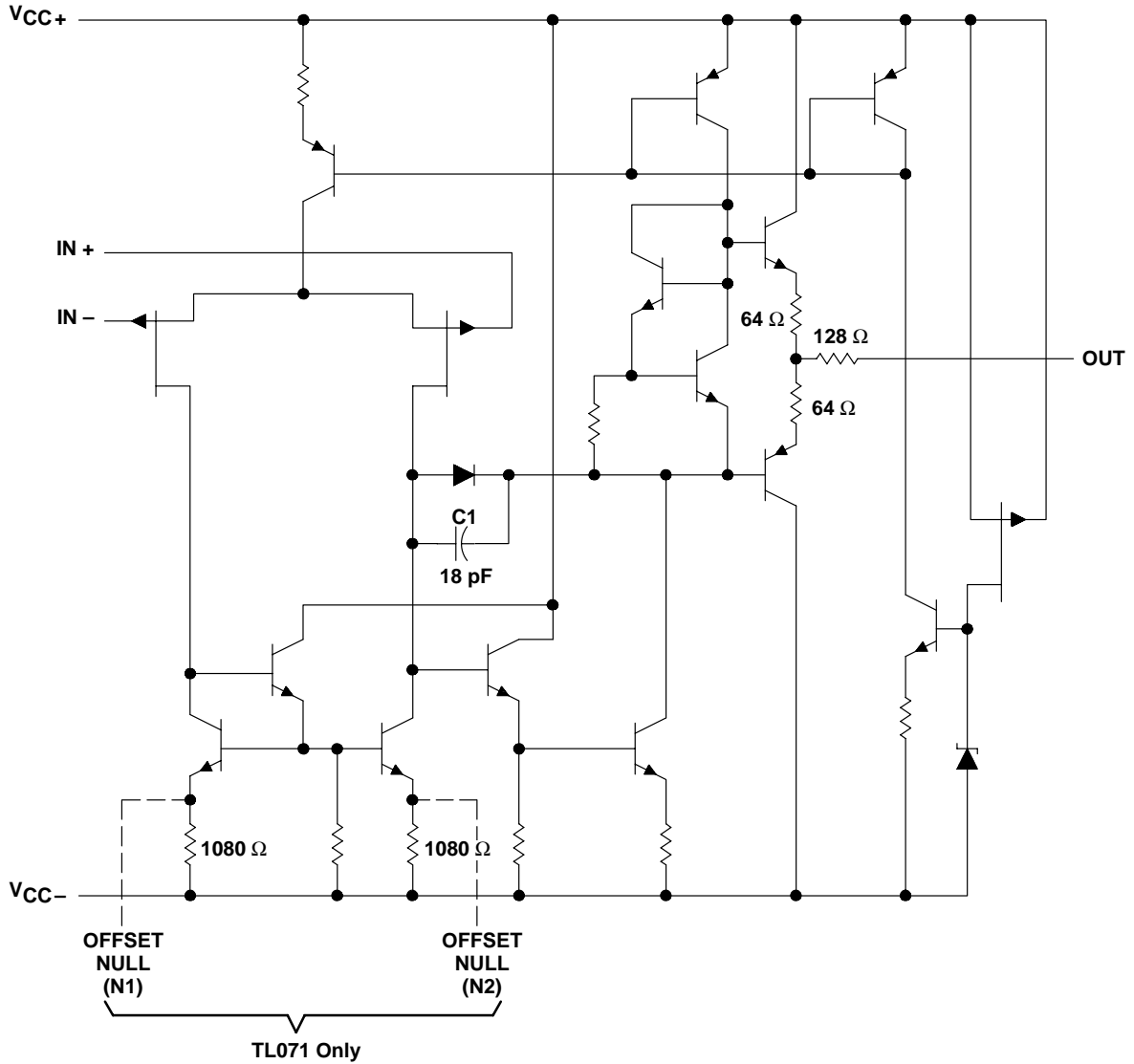

All component values shown are nominal.

COMPONENT COUNT†			
COMPONENT TYPE	TL071	TL072	TL074
Resistors	11	22	44
Transistors	14	28	56
JFET	2	4	6
Diodes	1	2	4
Capacitors	1	2	4
epi-FET	1	2	4

† Includes bias and trim circuitry

electrical characteristics, $V_{CC\pm} = \pm 15$ V (unless otherwise noted)

PARAMETER	TEST CONDITIONS†	T_A ‡	TL071C TL072C TL074C			TL071AC TL072AC TL074AC			TL071BC TL072BC TL074BC			TL0711 TL0721 TL0741			UNIT
			MIN	TYP	MAX	MIN	TYP	MAX	MIN	TYP	MAX	MIN	TYP	MAX	
V_{IO} Input offset voltage	$V_O = 0, R_S = 50 \Omega$	25°C		3	10		3	6		2	3		3	6	mV
		Full range			13			7.5			5			8	
α_{VIO} Temperature coefficient of input offset voltage	$V_O = 0, R_S = 50 \Omega$	Full range		18			18			18			18	$\mu V/^\circ C$	
I_{IO} Input offset current	$V_O = 0$	25°C		5	100		5	100		5	100		5	100	pA
		Full range			10			2			2			2	nA
I_{IB} Input bias current§	$V_O = 0$	25°C		65	200		65	200		65	200		65	200	pA
		Full range			7			7			7			20	nA
V_{ICR} Common-mode input voltage range		25°C	± 11	-12 to 15		± 11	-12 to 15		± 11	-12 to 15		± 11	-12 to 15	V	
V_{OM} Maximum peak output voltage swing	$R_L = 10 k\Omega$	25°C	± 12	± 13.5		± 12	± 13.5		± 12	± 13.5		± 12	± 13.5	V	
	$R_L \geq 10 k\Omega$	Full range	± 12			± 12			± 12			± 12			
	$R_L \geq 2 k\Omega$		± 10			± 10			± 10			± 10			
A_{VD} Large-signal differential voltage amplification	$V_O = \pm 10$ V, $R_L \geq 2 k\Omega$	25°C	25	200		50	200		50	200		50	200	V/mV	
		Full range	15			25			25			25			
B_1 Unity-gain bandwidth		25°C		3			3			3			3	MHz	
r_i Input resistance		25°C		10^{12}			10^{12}			10^{12}			10^{12}	Ω	
CMRR Common-mode rejection ratio	$V_{IC} = V_{ICRmin}, V_O = 0, R_S = 50 \Omega$	25°C	70	100		75	100		75	100		75	100	dB	
k_{SVR} Supply-voltage rejection ratio ($\Delta V_{CC\pm}/\Delta V_{IO}$)	$V_{CC} = \pm 9$ V to ± 15 V, $V_O = 0, R_S = 50 \Omega$	25°C	70	100		80	100		80	100		80	100	dB	
I_{CC} Supply current (each amplifier)	$V_O = 0, \text{No load}$	25°C		1.4	2.5		1.4	2.5		1.4	2.5		1.4	2.5	mA
V_{O1}/V_{O2} Crosstalk attenuation	$A_{VD} = 100$	25°C		120			120			120			120	dB	

† All characteristics are measured under open-loop conditions with zero common-mode voltage unless otherwise specified.

‡ Full range is $T_A = 0^\circ C$ to $70^\circ C$ for TL07_C, TL07_AC, TL07_BC and is $T_A = -40^\circ C$ to $85^\circ C$ for TL07_I.

§ Input bias currents of a FET-input operational amplifier are normal junction reverse currents, which are temperature sensitive as shown in Figure 4. Pulse techniques must be used that maintain the junction temperature as close to the ambient temperature as possible.

**TL071, TL071A, TL071B, TL072
TL072A, TL072B, TL074, TL074A, TL074B
LOW-NOISE JFET-INPUT OPERATIONAL AMPLIFIERS**

SLOS080D – SEPTEMBER 1978 – REVISED AUGUST 1996

electrical characteristics, $V_{CC\pm} = \pm 15$ V (unless otherwise noted)

PARAMETER	TEST CONDITIONS†	T_A ‡	TL071M TL072M			TL074M			UNIT
			MIN	TYP	MAX	MIN	TYP	MAX	
V_{IO} Input offset voltage	$V_O = 0, R_S = 50 \Omega$	25°C	3	6		3	9	mV	
		Full range			9		15		
α_{VIO} Temperature coefficient of input offset voltage	$V_O = 0, R_S = 50 \Omega$	Full range	18			18			$\mu V/^\circ C$
I_{IO} Input offset current	$V_O = 0$	25°C	5	100		5	100	pA	
		Full range			20		20	nA	
I_{IB} Input bias current‡	$V_O = 0$	25°C	65	200		65	200	pA	
		Full range			50		50	nA	
V_{ICR} Common-mode input voltage range		25°C	± 11	-12 to 15		± 11	-12 to 15	V	
V_{OM} Maximum peak output voltage swing	$R_L = 10 k\Omega$	25°C	± 12	± 13.5		± 12	± 13.5	V	
	$R_L \geq 10 k\Omega$	Full range	± 12			± 12			
	$R_L \geq 2 k\Omega$		± 10			± 10			
A_{VD} Large-signal differential voltage amplification	$V_O = \pm 10$ V, $R_L \geq 2 k\Omega$	25°C	35	200		35	200	V/mV	
		Full range	15			15			
B_1 Unity-gain bandwidth	$T_A = 25^\circ C$		3			3			MHz
r_i Input resistance	$T_A = 25^\circ C$		10^{12}			10^{12}			Ω
CMRR Common-mode rejection ratio	$V_{IC} = V_{ICRmin}, V_O = 0, R_S = 50 \Omega$	25°C	80	86		80	86	dB	
k_{SVR} Supply-voltage rejection ratio ($\Delta V_{CC\pm}/\Delta V_{IO}$)	$V_{CC} = \pm 9$ V to ± 15 V, $V_O = 0, R_S = 50 \Omega$	25°C	80	86		80	86	dB	
I_{CC} Supply current (each amplifier)	$V_O = 0, \text{No load}$	25°C	1.4	2.5		1.4	2.5	mA	
V_{O1}/V_{O2} Crosstalk attenuation	$A_{VD} = 100$	25°C	120			120			dB

† Input bias currents of a FET-input operational amplifier are normal junction reverse currents, which are temperature sensitive as shown in Figure 4. Pulse techniques must be used that will maintain the junction temperature as close to the ambient temperature as possible.

‡ All characteristics are measured under open-loop conditions with zero common-mode voltage unless otherwise specified. Full range is $T_A = -55^\circ C$ to $125^\circ C$.



**TL071, TL071A, TL071B, TL072
TL072A, TL072B, TL074, TL074A, TL074B**
LOW-NOISE JFET-INPUT OPERATIONAL AMPLIFIERS

SLOS080D – SEPTEMBER 1978 – REVISED AUGUST 1996

operating characteristics, $V_{CC\pm} = \pm 15\text{ V}$, $T_A = 25^\circ\text{C}$

PARAMETER	TEST CONDITIONS	TL07xM			ALL OTHERS			UNIT
		MIN	TYP	MAX	MIN	TYP	MAX	
SR	Slew rate at unity gain $V_I = 10\text{ V}$, $C_L = 100\text{ pF}$, $R_L = 2\text{ k}\Omega$, See Figure 1	5	13		8	13		$\text{V}/\mu\text{s}$
t_r	Rise time overshoot factor $V_I = 20\text{ mV}$, $C_L = 100\text{ pF}$, $R_L = 2\text{ k}\Omega$, See Figure 1	0.1			0.1			μs
		20%			20%			
V_n	Equivalent input noise voltage $R_S = 20\ \Omega$	$f = 1\text{ kHz}$			18			$\text{nV}/\sqrt{\text{Hz}}$
		$f = 10\text{ Hz to } 10\text{ kHz}$			4			μV
I_n	Equivalent input noise current $R_S = 20\ \Omega$, $f = 1\text{ kHz}$	0.01			0.01			$\text{pA}/\sqrt{\text{Hz}}$
THD	Total harmonic distortion $V_{\text{rms}} = 6\text{ V}$, $R_L \geq 2\text{ k}\Omega$, $f = 1\text{ kHz}$, $A_{VD} = 1$, $R_S \leq 1\text{ k}\Omega$,	0.003%			0.003%			

PARAMETER MEASUREMENT INFORMATION

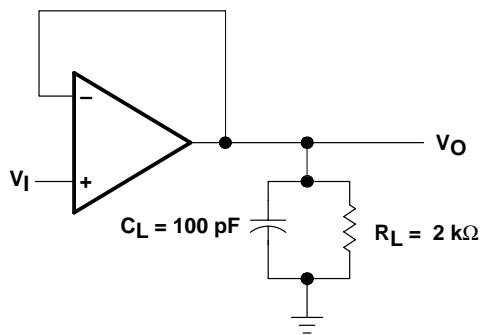

Figure 1. Unity-Gain Amplifier

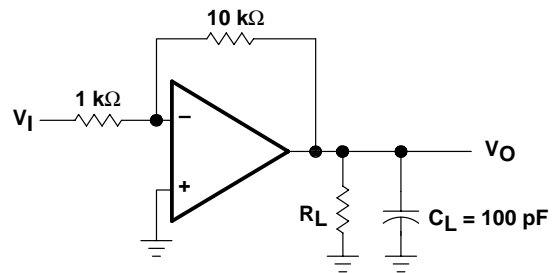

Figure 2. Gain-of-10 Inverting Amplifier

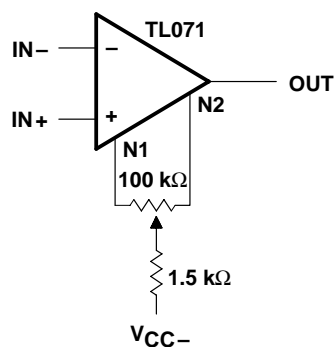

Figure 3. Input Offset Voltage Null Circuit

TYPICAL CHARACTERISTICS

Table of Graphs

		FIGURE	
I_{IB}	Input bias current	vs Free-air temperature	4
V_{OM}	Maximum output voltage	vs Frequency	5, 6, 7
		vs Free-air temperature	8
		vs Load resistance	9
		vs Supply voltage	10
A_{VD}	Large-signal differential voltage amplification	vs Free-air temperature	11
		vs Frequency	12
	Phase shift	vs Frequency	12
	Normalized unity-gain bandwidth	vs Free-air temperature	13
	Normalized phase shift	vs Free-air temperature	13
CMRR	Common-mode rejection ratio	vs Free-air temperature	14
I_{CC}	Supply current	vs Supply voltage	15
		vs Free-air temperature	16
P_D	Total power dissipation	vs Free-air temperature	17
		Normalized slew rate	vs Free-air temperature
V_n	Equivalent input noise voltage	vs Frequency	19
THD	Total harmonic distortion	vs Frequency	20
		Large-signal pulse response	vs Time
V_O	Output voltage	vs Elapsed time	22

TYPICAL CHARACTERISTICS†

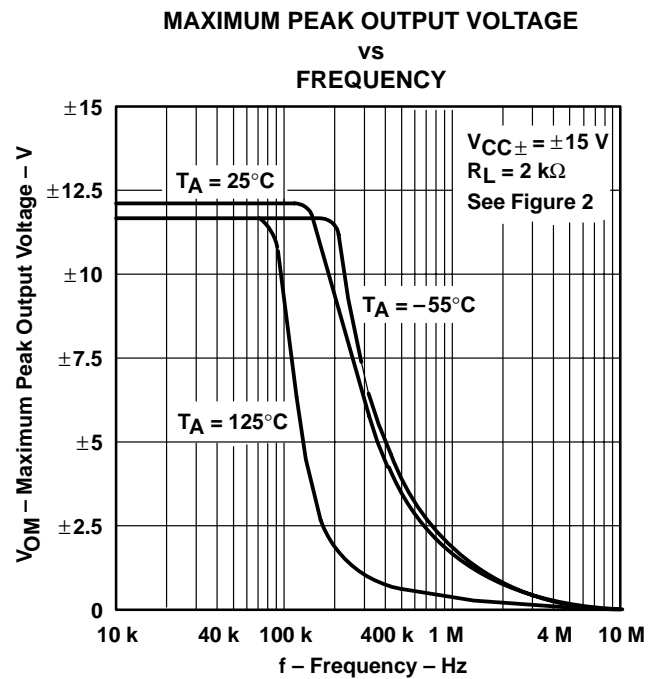
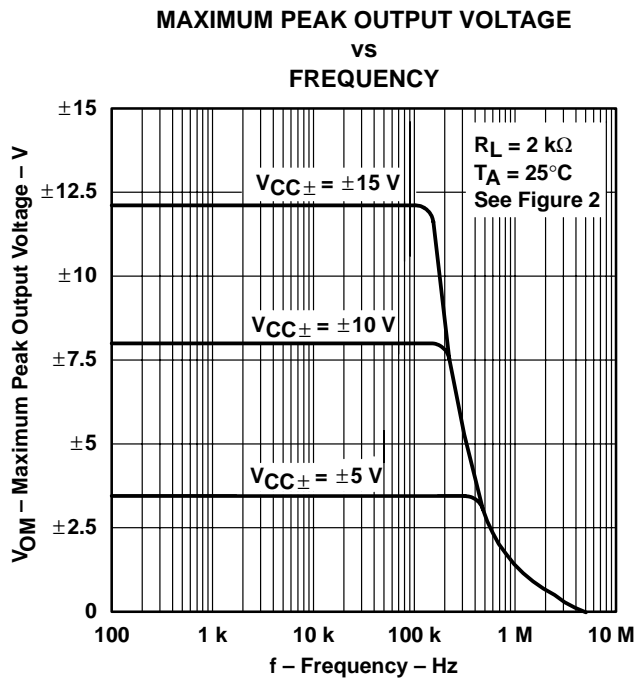
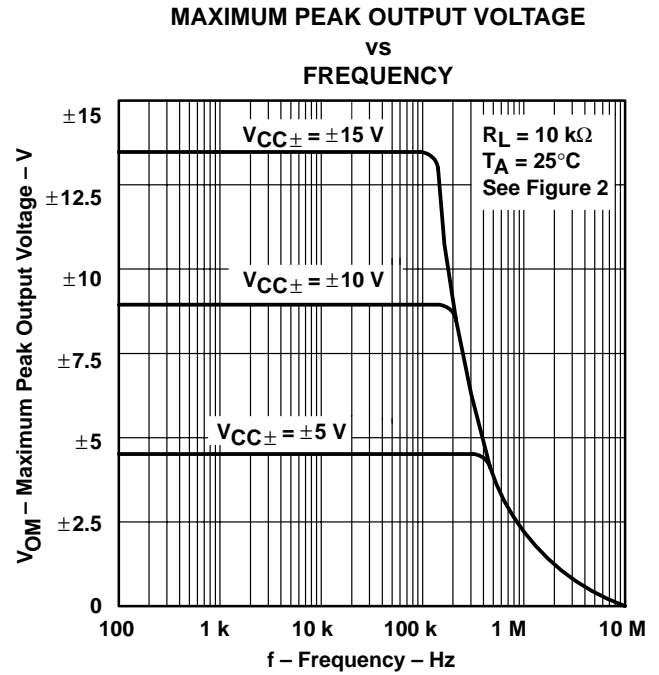
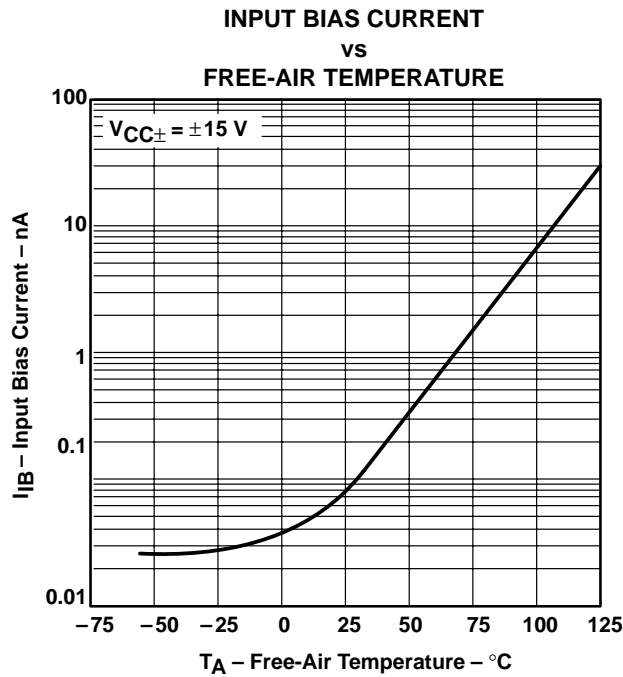

† Data at high and low temperatures are applicable only within the rated operating free-air temperature ranges of the various devices.

TYPICAL CHARACTERISTICS†

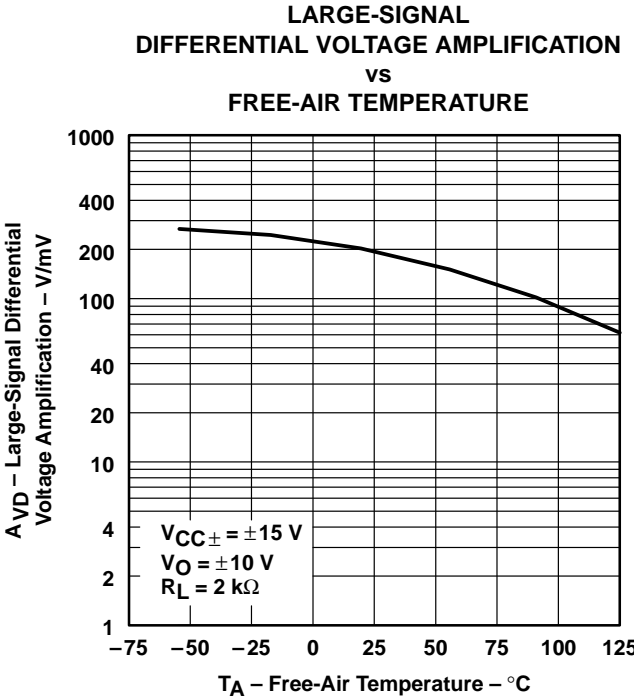
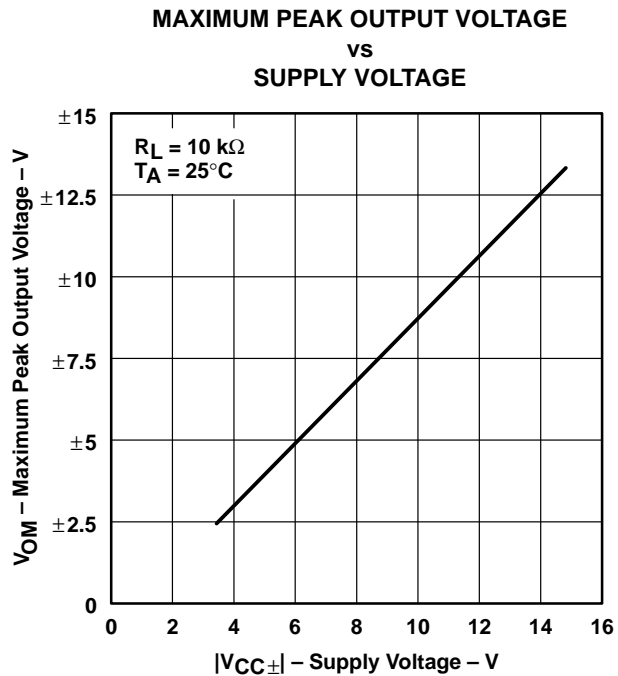
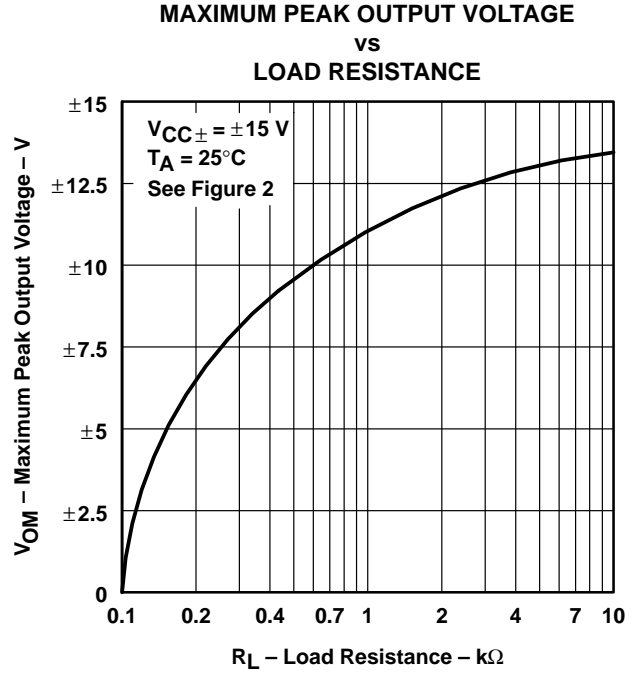
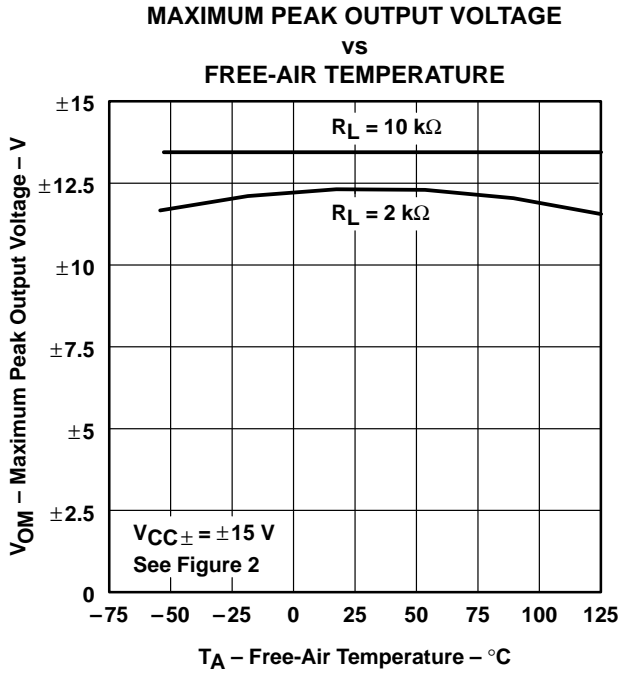

† Data at high and low temperatures are applicable only within the rated operating free-air temperature ranges of the various devices.

TYPICAL CHARACTERISTICS†
 LARGE-SIGNAL
 DIFFERENTIAL VOLTAGE AMPLIFICATION
 AND PHASE SHIFT
 vs
 FREQUENCY

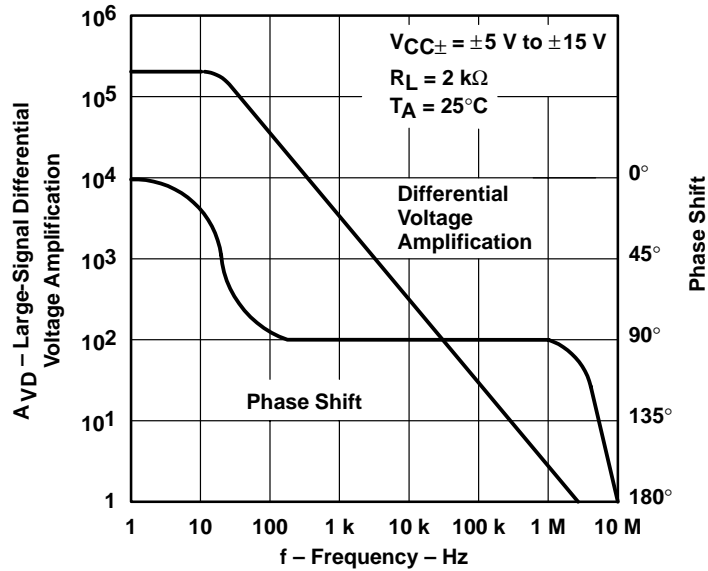

Figure 12

NORMALIZED UNITY-GAIN BANDWIDTH
 AND PHASE SHIFT
 vs
 FREE-AIR TEMPERATURE

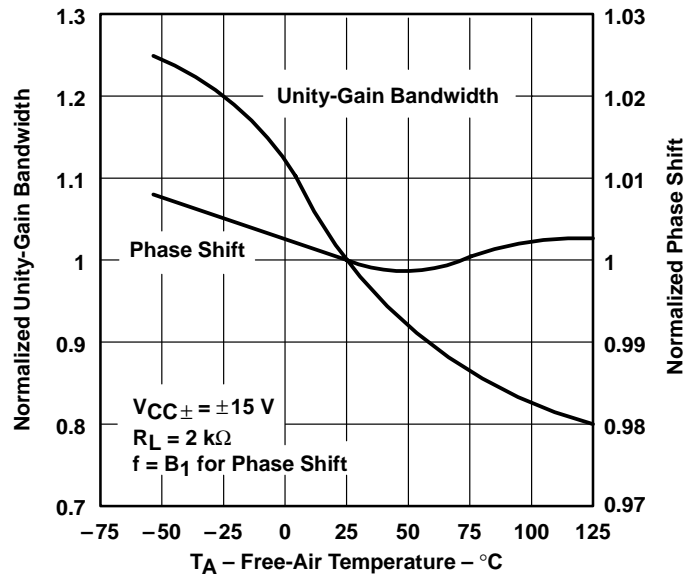

Figure 13

† Data at high and low temperatures are applicable only within the rated operating free-air temperature ranges of the various devices.

TYPICAL CHARACTERISTICS†

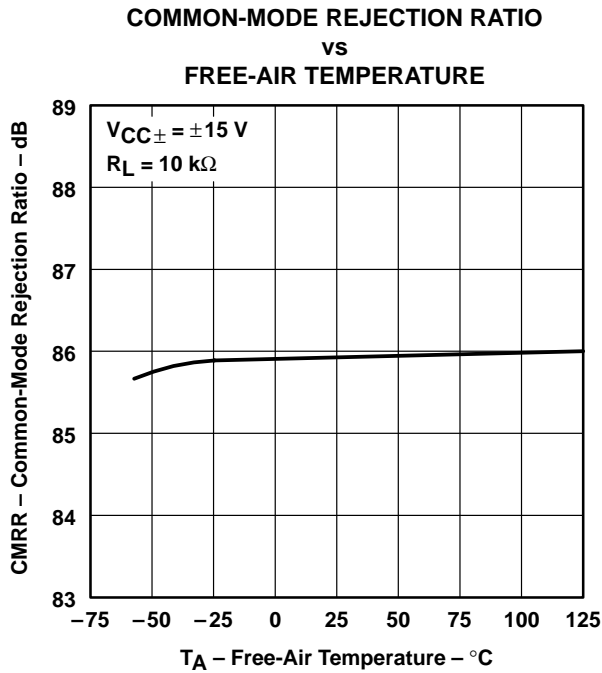

Figure 14

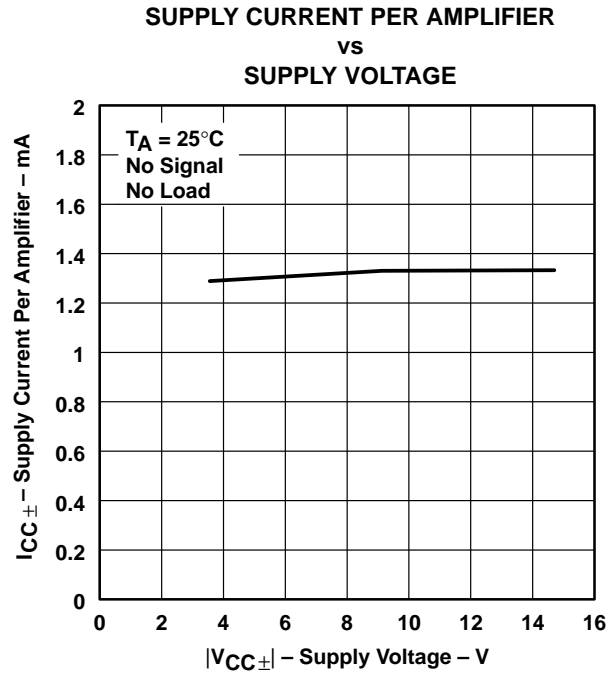

Figure 15

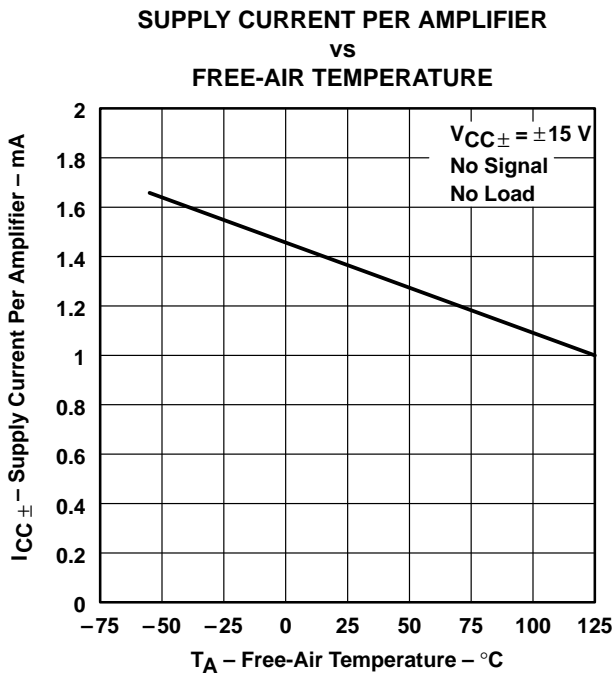

Figure 16

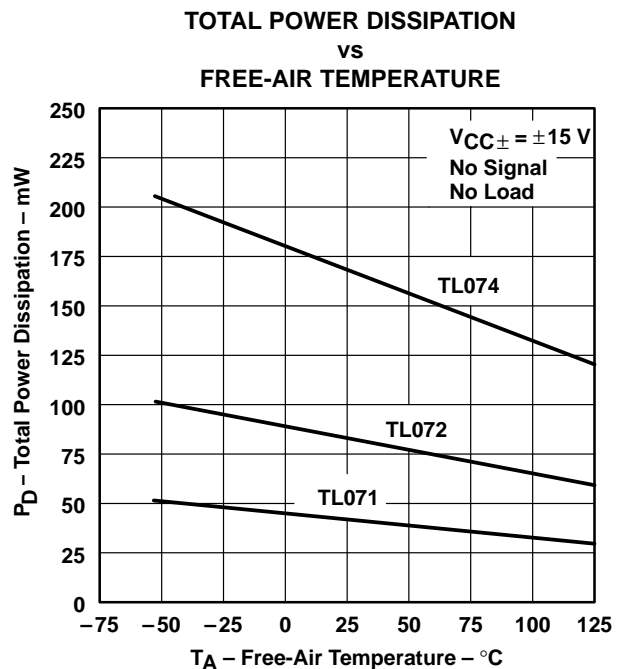

Figure 17

† Data at high and low temperatures are applicable only within the rated operating free-air temperature ranges of the various devices.

TYPICAL CHARACTERISTICS

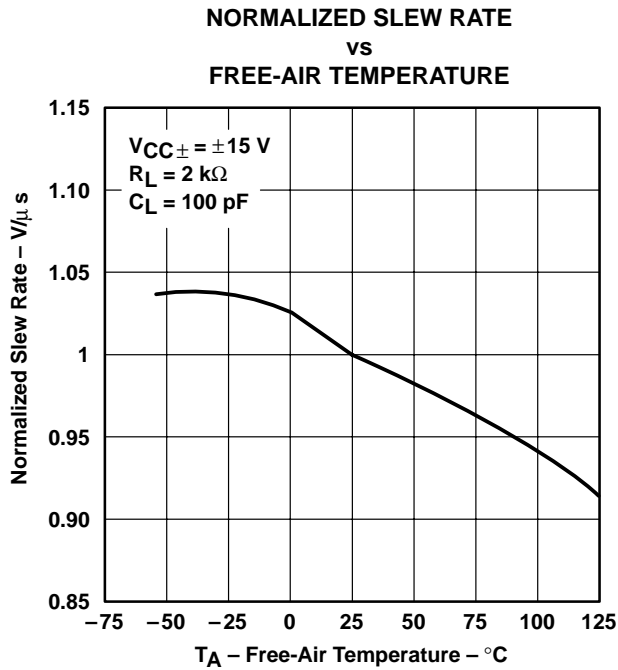

Figure 18

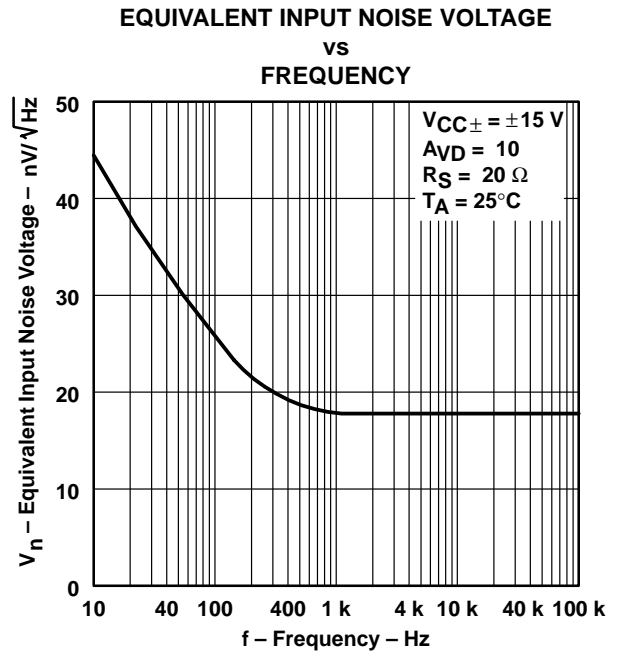

Figure 19

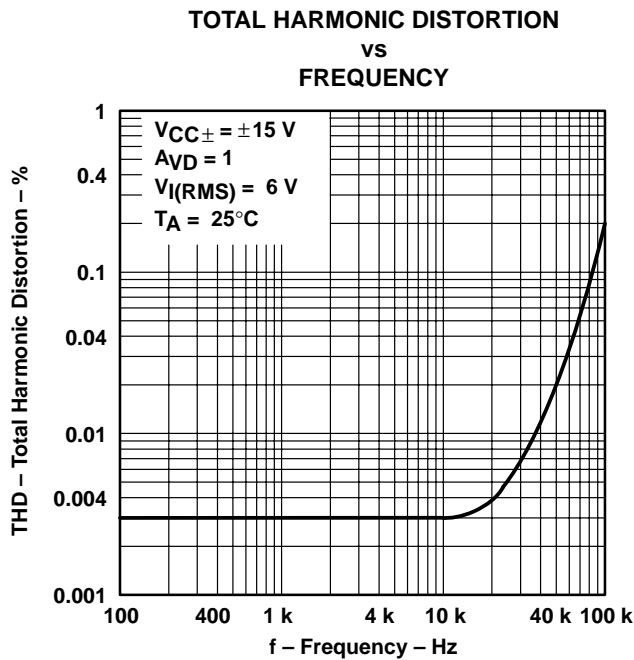

Figure 20

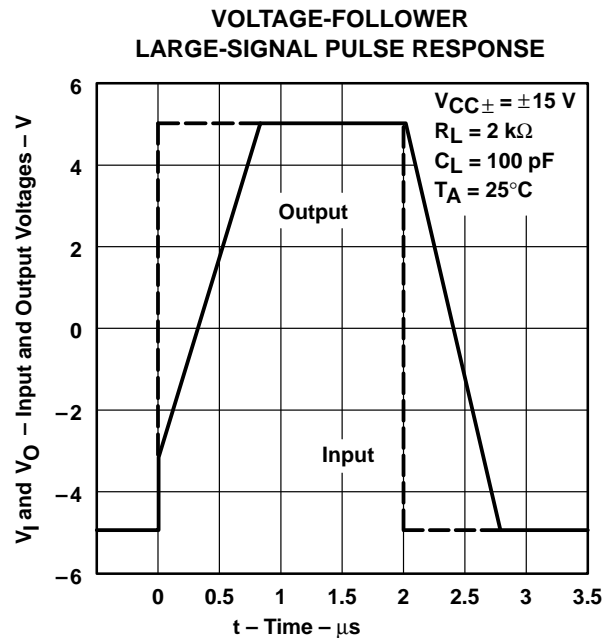

Figure 21

TYPICAL CHARACTERISTICS

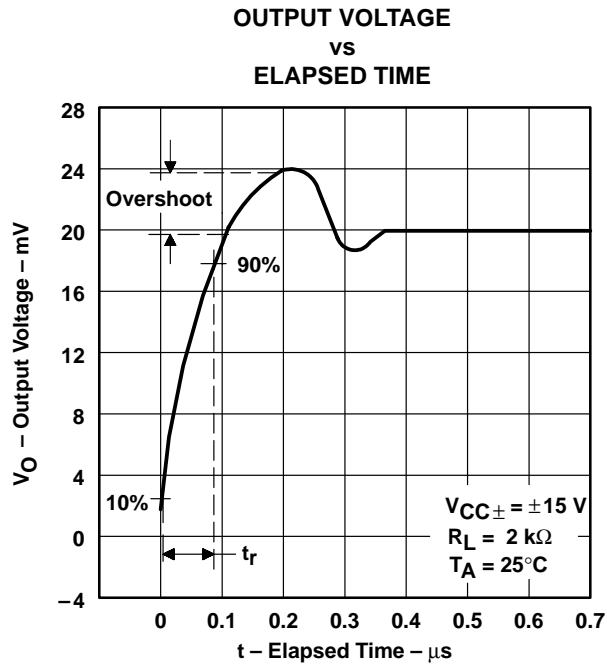

Figure 22

APPLICATION INFORMATION

Table of Application Diagrams

APPLICATION DIAGRAM	PART NUMBER	FIGURE
0.5-Hz square-wave oscillator	TL071	23
High-Q notch filter	TL071	24
Audio-distribution amplifier	TL074	25
100-kHz quadrature oscillator	TL072	26
AC amplifier	TL071	27

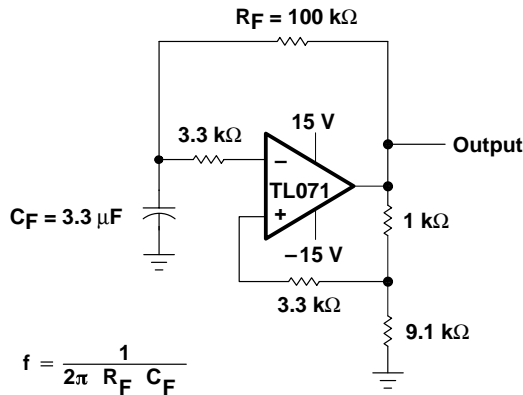

Figure 23. 0.5-Hz Square-Wave Oscillator

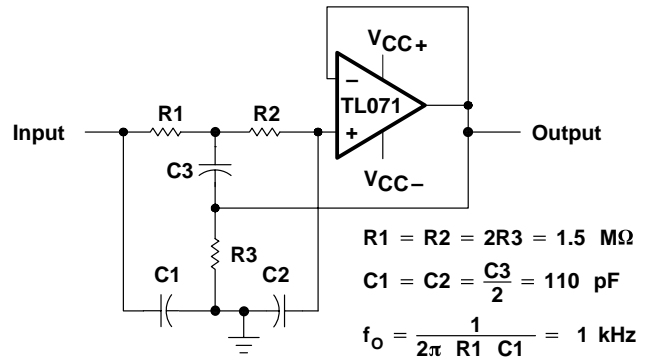

Figure 24. High-Q Notch Filter

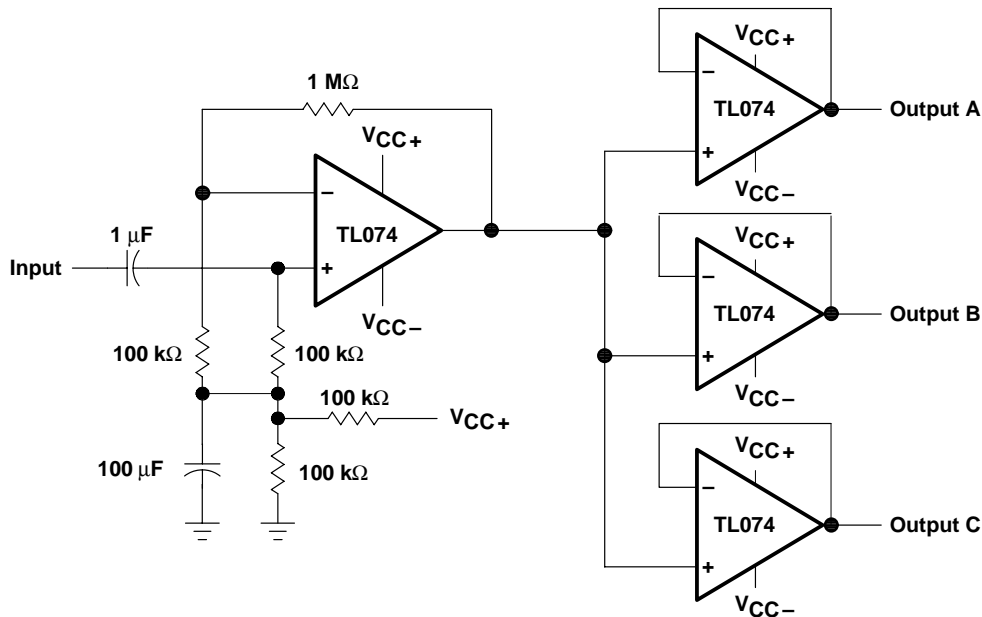
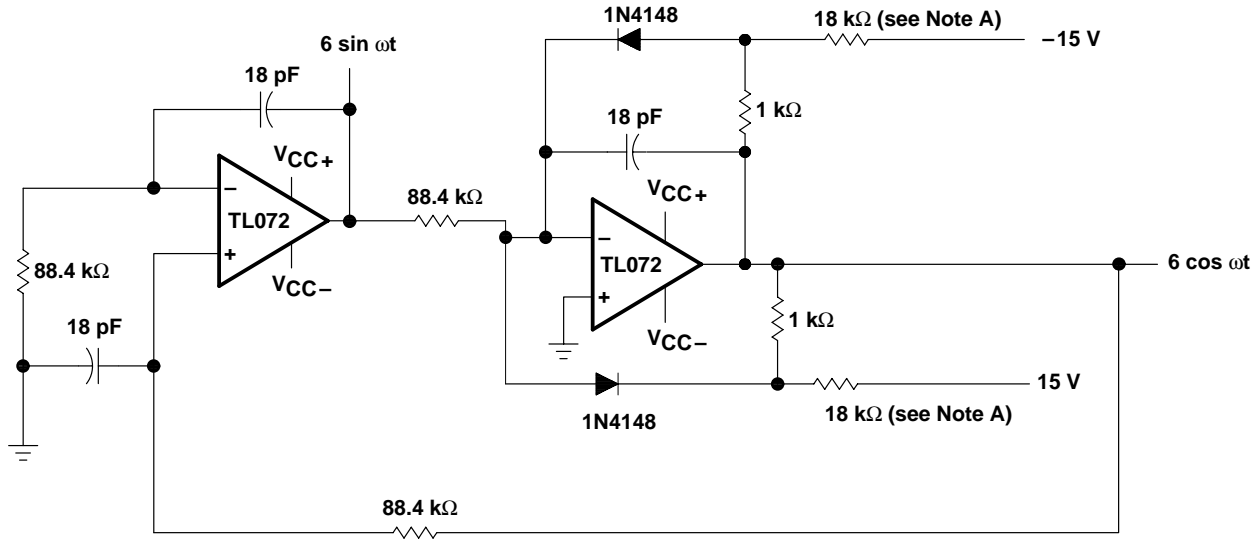

Figure 25. Audio-Distribution Amplifier

APPLICATION INFORMATION



NOTE A: These resistor values may be adjusted for a symmetrical output.

Figure 26. 100-kHz Quadrature Oscillator

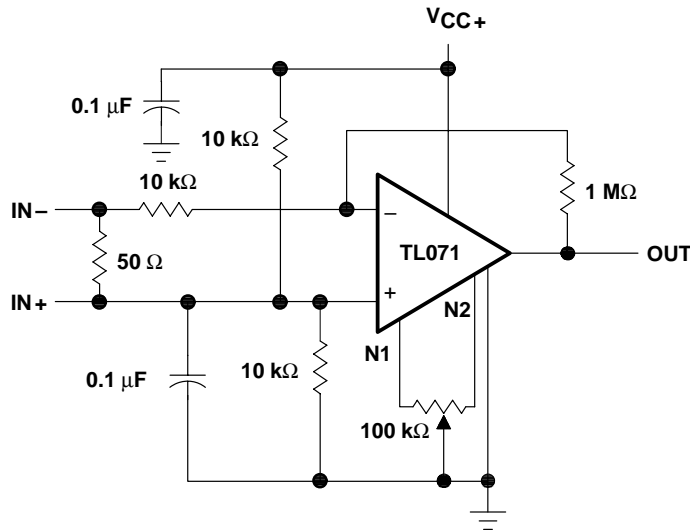

Figure 27. AC Amplifier

IMPORTANT NOTICE

Texas Instruments (TI) reserves the right to make changes to its products or to discontinue any semiconductor product or service without notice, and advises its customers to obtain the latest version of relevant information to verify, before placing orders, that the information being relied on is current.

TI warrants performance of its semiconductor products and related software to the specifications applicable at the time of sale in accordance with TI's standard warranty. Testing and other quality control techniques are utilized to the extent TI deems necessary to support this warranty. Specific testing of all parameters of each device is not necessarily performed, except those mandated by government requirements.

Certain applications using semiconductor products may involve potential risks of death, personal injury, or severe property or environmental damage ("Critical Applications").

TI SEMICONDUCTOR PRODUCTS ARE NOT DESIGNED, INTENDED, AUTHORIZED, OR WARRANTED TO BE SUITABLE FOR USE IN LIFE-SUPPORT APPLICATIONS, DEVICES OR SYSTEMS OR OTHER CRITICAL APPLICATIONS.

Inclusion of TI products in such applications is understood to be fully at the risk of the customer. Use of TI products in such applications requires the written approval of an appropriate TI officer. Questions concerning potential risk applications should be directed to TI through a local SC sales office.

In order to minimize risks associated with the customer's applications, adequate design and operating safeguards should be provided by the customer to minimize inherent or procedural hazards.

TI assumes no liability for applications assistance, customer product design, software performance, or infringement of patents or services described herein. Nor does TI warrant or represent that any license, either express or implied, is granted under any patent right, copyright, mask work right, or other intellectual property right of TI covering or relating to any combination, machine, or process in which such semiconductor products or services might be or are used.