

FEATURES

- Fully Differential High Impedance Voltage Sensing
- Accurate Current Amplifier for Precise Current Sharing
- Opto Coupler Driving Capability
- 1.25% Trimmed Reference
- Master Status Indication
- 4.5-V to 35-V Operation

SOIC-16 DW PACKAGE
(TOP VIEW)

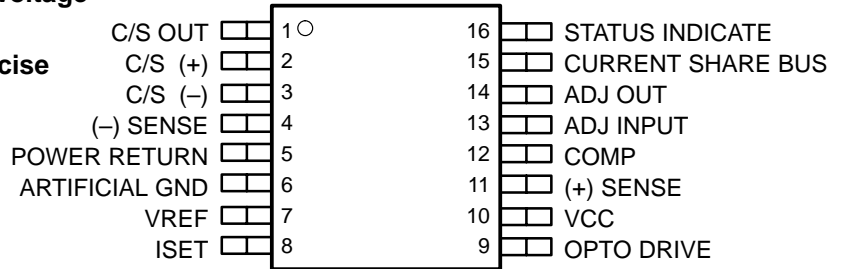

PLCC-20, LCC-20,
Q OR L PACKAGE
(TOP VIEW)

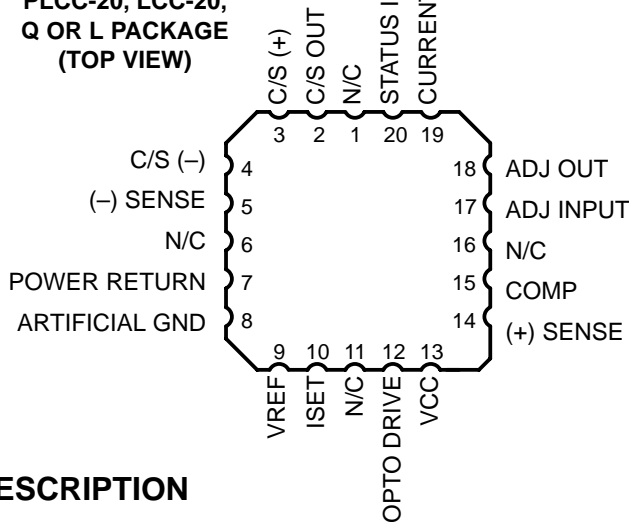

DIL-16 J or N PACKAGE
(TOP VIEW)

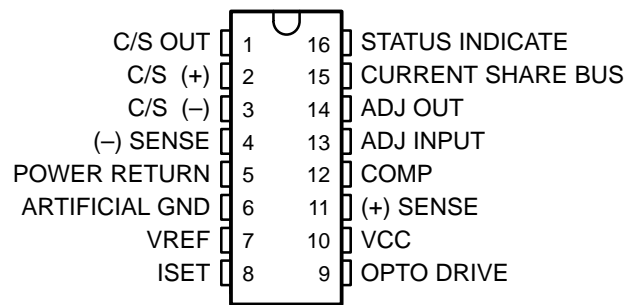

DESCRIPTION

The UCx907 family of load share controller ICs provides all the necessary features to allow multiple-independent-power modules to be paralleled such that each module supplies only its proportionate share to total-load current.

This sharing is accomplished by controlling each module's power stage with a command generated from a voltage-feedback amplifier whose reference can be independently adjusted in response to a common-share-bus voltage. By monitoring the current from each module, the current share bus circuitry determines which paralleled module would normally have the highest output current and, with the designation of this unit as the master, adjusts all the other modules to increase their output current to within 2.5% of that of the master.

The current share bus signal interconnecting all the paralleled modules is a low-impedance, noise-insensitive line which will not interfere with allowing each module to act independently should the bus become open or shorted to ground. The UC3907 controller will reside on the output side of each power module and its overall function is to supply a voltage feedback loop. The specific architecture of the power stage is unimportant. Either switching or linear designs may be utilized and the control signal may be either directly coupled or isolated through the use of an optocoupler or other isolated medium.

Other features of the UC3907 include 1.25% accurate reference: a low-loss, fixed-gain current-sense amplifier, a fully differential, high-impedance voltage sensing capability, and a status indicator to designate which module is performing as master.



Please be aware that an important notice concerning availability, standard warranty, and use in critical applications of Texas Instruments semiconductor products and disclaimers thereto appears at the end of this data sheet.

PRODUCTION DATA information is current as of publication date. Products conform to specifications per the terms of Texas Instruments standard warranty. Production processing does not necessarily include testing of all parameters.

UC1907, UC2907, UC3907 LOAD SHARE CONTROLLER

SLUS165C – MARCH 1999 - REVISED JANUARY 2002

block diagram

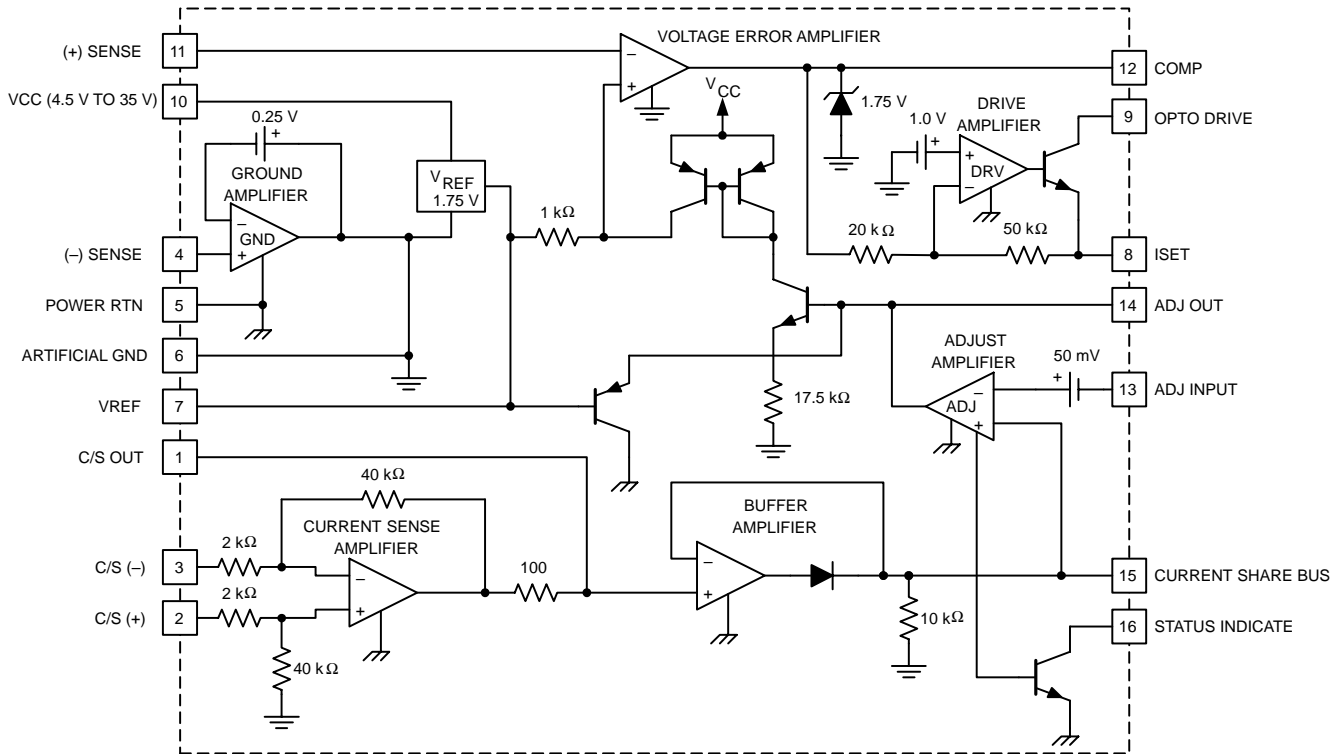

absolute maximum ratings over operating free-air temperature (unless otherwise noted)†

Supply voltage	35 V
Opto out voltage	35 V
Opto out current	20 mA
Status indicate sink current	20 mA
C/S input voltage	35 V
Share bus voltage	-0.3 V to 35 V
Other analog inputs and outputs (zener clamped) maximum forced voltage	-0.3 V to 10 V
Other analog inputs and outputs (zener clamped) maximum forced current	±10 mA
Ground amp sink current	50 mA
Pins 1, 9, 12, 15 sink current	20 mA
Storage temperature range, T_{stg}	-65°C to 150°C
Junction temperature, T_J	-55°C to 150°C
Lead temperature (solder 10 seconds)	300°C

† Pin Nos. refer to 16 Pin DIL Package.

‡ Currents are positive into, negative out of the specified terminal. Consult packaging section of databook for thermal limitations and considerations of package.

UC1907, UC2907, UC3907 LOAD SHARE CONTROLLER

SLUS165C – MARCH 1999 - REVISED JANUARY 2002

electrical characteristics, these specifications apply for $T_A = -55^\circ\text{C}$ to 125°C for UC1907, -40°C to 85°C for UC2907, and 0°C to 70°C for UC3907, $V_{IN} = 15\text{ V}$, $T_A = T_J$ (unless otherwise stated)

PARAMETER	TEST CONDITIONS	MIN	TYP	MAX	UNITS
Voltage Amp Section					
Input voltage	COMP = 1 V, $T_A = 25^\circ\text{C}$	1.975	2.000	2.025	V
	COMP = 1 V, over temp	1.960	2.000	2.040	V
Line regulation	$V_{IN} = 4.5\text{ V to }35\text{ V}$			15	mV
Load regulation	I_L reference = 0.0 mA to -10 mA			10	mV
Long term stability	$T_A = 125^\circ\text{C}$, 1000hrs See Note 2		5	25	mV
Total output variation	Line, load, temp	1.960		2.040	
Input adjust range	ADJ OUT from max high to max low	85	100	115	mV
Input bias current		-1			μA
Open loop gain	COMP = 0.75 V to 1.5 V	65			dB
Unity gain bandwidth	$T_A = 25^\circ\text{C}$ See Note 2	700			kHz
Output sink current	(+) SENSE = 2.2 V, COMP = 1 V	6	15		mA
Output source current	(+) SENSE = 1.8 V, COMP = 1 V	400	600		μA
V_{OUT} high	(+) SENSE = 1.8 V, $I_L = -400\ \mu\text{A}$	1.85	2		V
V_{OUT} low	(+) SENSE = 2.2 V, $I_L = 1\text{ mA}$		0.15	0.40	V
Reference Section					
Output voltage	$T_A = 25^\circ\text{C}$	1.970	2.000	2.030	V
	Over operating temp	1.955	2.000	2.045	V
Short circuit current	$V_{REF} = 0.0\text{ V}$	-15	-30	-60	mA
Ground Amp Section					
Output voltage		200	250	300	mV
Common mode variation	(-) SENSE from 0.0 V to 2 V			5	mV
Load regulation	$I_L = 0.0\text{ mA to }20\text{ mA}$, $T_A = 25^\circ\text{C}$			10	mV
	$I_L = 0.0\text{ mA to }20\text{ mA}$, over temp			15	mV
Adjust Amp Section					
Input offset voltage	ADJ OUT = 1.5 V, $V_{CM} = 0.0\text{ V}$	40	50	60	mV
Input bias current		-2			μA
Open loop gain	$1.5\text{ V} \leq \text{ADJ OUT} \leq 2.25\text{ V}$	65			dB
Unity gain bandwidth	$T_A = 25^\circ\text{C}$, $C_{OUT} = 1\ \mu\text{F}$ See Note 2		500		Hz
Transconductance	$I_{OUT} = -10\ \mu\text{A to }10\ \mu\text{A}$, $V_{OUT} = 1.5\text{ V}$	1.7	3	4.5	ms
Output sink current	$V_{ID} = 0.0\text{ V}$, ADJ OUT = 1.5 V	55	135	225	μA
Output source current	$V_{ID} = 250\text{ mV}$, ADJ OUT = 1.5 V	110	200	350	μA
V_{OUT} high	$V_{ID} = 250\text{ mV}$, $I_{OUT} = -50\text{ mA}$	2.20	2.70	2.90	V
V_{OUT} low	$V_{ID} = 0.0\text{ V}$, $I_{OUT} = 50\text{ mA}$		0.75	1.15	V
Common mode rejection ratio	$V_{CM} = 0.0\text{ to }10\text{ V}$	70			dB
Output gain to V/A	V_{OUT} ADJ OUT = 1.5 V to 2 V, $\Delta(+)$ SENSE/ Δ ADJ OUT	50	57	64	mV/V

NOTE 1: Unless otherwise specified all voltages are with respect to (-) SENSE. Currents are positive into, negative out of the specified terminal.

NOTE 2: Ensured by design. Not production tested.

UC1907, UC2907, UC3907 LOAD SHARE CONTROLLER

SLUS165C – MARCH 1999 - REVISED JANUARY 2002

electrical characteristics, these specifications apply for $T_A = -55^{\circ}\text{C}$ to 125°C for UC1907, -40°C to 85°C for UC2907, and 0°C to 70°C for UC3907, $V_{IN} = 15\text{ V}$, $T_A = T_J$ (unless otherwise stated)

PARAMETER	TEST CONDITIONS	MIN	TYP	MAX	UNITS
Current Amp Section					
Gain	$V_{CM} = 0.0\text{ V}$, $V_{ID} = 50\text{ mV to }100\text{ mV}$	19.2	19.6	20.1	V/V
Output voltage	$V_{C/S (+)} = V_{C/S (-)} = 0.0\text{ V}$, $T_A = 25^{\circ}\text{C}$	210	250	290	mV
	$V_{C/S (+)} = V_{C/S (-)} = 0.0\text{ V}$, over temp	180	250	330	mV
Input offset change with common mode input	$V_{CM} = 0\text{ V to }13\text{ V}$			600	$\mu\text{V/V}$
V_{OUT} high	$V_{ID} = 1\text{ V}$	10	14.5		V
V_{OUT} low	$V_{ID} = -1\text{ V}$, $I_L = 1\text{ mA}$		350	450	mV
Power supply rejection ratio	$V_{IN} = 4.5\text{ V to }35\text{ V}$, $V_{CM} = 0.0\text{ V}$	60			dB
Slew rate			0.4		V/ μs
Drive Amp Section $R_{SET} = 500\ \Omega$ to Artificial GND, Opto Drive = 15 V					
Voltage gain	COMP = 0.5 V to 1 V	2.3	2.5	2.6	V/V
I_{SET} V_{OUT} high	(+) SENSE = 2.2 V	3.8	4.1	4.4	V
I_{SET} V_{OUT} low	(+) SENSE = 1.8 V		270	300	mV
Opto out voltage range		4		35	V
Zero current input threshold		1.55	1.65	1.75	V
Buffer Amp Section					
Input offset voltage	Input = 1 V			5	mV
Output off impedance	Input = 1 V, output = 1.5 V to 2 V	5	10	20	k Ω
Output source current	Input = 1 V, output = 0.5 V	6	15		mA
Common mode rejection ratio	$V_{CM} = 0.3\text{ V to }10\text{ V}$	70			dB
Power supply rejection ratio	$V_{IN} = 4.5\text{ V to }35\text{ V}$	70			dB
Under Voltage Lockout Section					
Startup threshold			3.7	4.4	V
Threshold hysteresis			200		mV
Status Indicate Section					
V_{OUT} low	ADJ OUT = current share bus		0.2	0.5	V
Output leakage	ADJ OUT = 1 V, $V_{OUT} = 35\text{ V}$		0.1	5	μA
Total Stand by Current Section					
Startup current	$V_{IN} = UVLO - 0.2\text{ V}$		3	5	mA
Operating current	$V_{IN} = 35\text{ V}$		6	10	mA

NOTE 1: Unless otherwise specified all voltages are with respect to (-) SENSE. Currents are positive into, negative out of the specified terminal.

NOTE 2: Ensured by design. Not production tested.

pin assignments

(–) SENSE: (Pin 4) This is a high-impedance pin allowing remote sensing of the system ground, bypassing any voltage drops which might appear in the power return line. This point should be considered as the true ground. Unless otherwise stated, all voltages are with respect to this point.

Artificial Ground: (Pin 6) This is a low-impedance-circuit ground which is exactly 250 mV above the (–) SENSE terminal. This offset allows the ground buffer amplifier negative headroom to return all the control bias and operating currents while maintaining a high impedance at the (–) SENSE input.

Power RTN: (Pin 5) This should be the most negative voltage available and can range from zero to 5 V below the (–) SENSE terminal. It should be connected as close to the power source as possible so that voltage drops across the return line and current-sensing impedances lie between this terminal and the (–) SENSE point.

VREF: (Pin 7) The internal voltage reference is a band-gap circuit set at 2.0 V with respect to the (–) SENSE input (1.75 V above the artificial ground), and an accuracy of $\pm 1.5\%$. This circuit, as well as all the other chip functions, will work over a supply voltage range of 4.5 V to 35 V allowing operation from unregulated dc, an auxiliary voltage, or the same output voltage that it is controlling. Under-voltage lockout has been included to insure proper startup by disabling internal bias currents until the reference rises into regulation.

Voltage Amplifier: (Pins 11, 12) This circuit is the feedback-control-gain stage for the power module's output-voltage regulation, and overall-loop compensation will normally be applied around this amplifier. Its output will swing from slightly above the ground return to an internal clamp of 2.0 V. The reference trimming is performed closed loop, and measured at pin 11, (+) SENSE. The value is trimmed to $2\text{ V} \pm 1.25\%$.

Drive Amplifier: (Pins 8, 9, 12) This amplifier is used as an inverting buffer between the voltage amplifier's output and the medium used to couple the feedback signal to the power controller. It has a fixed-voltage gain of 2.5 and is usually configured with a current-setting resistor to ground. This establishes a current-sinking output optimized to drive optical couplers biased at any voltage from 4.5 V to 35 V, with current levels up to 20 mA. The polarity of this stage is such that an increasing voltage at the voltage amplifier's sense input (as, for example, at turnon) will increase the opto's current. In a nonisolated application, a voltage signal ranging from 0.25 V to 4.1 V may be taken from the current-setting output but it should be noted that this voltage will also increase with increasing sense voltage and an external inverter may be required to obtain the correct feedback polarity.

Current Amplifier: (Pins 1, 2, 3) This amplifier has differential-sensing capability for use with an external shunt in the power-return line. The common mode range of its input will accommodate the full range between the power return point and $V_{CC}-2\text{ V}$ which will allow undefined-line impedances on either side of the current shunt. The gain is internally set at 20, giving the user the ability to establish the maximum-voltage drop across the current-sense resistor at any value between 50 mV and 500 mV. While the bandwidth of this amplifier may be reduced with the addition of an external-output capacitor to ground, in most cases this is not required as the compensation of the adjust amplifier will typically form the dominant pole in the adjust loop.

Buffer Amplifier: (Pins 1, 15) This amplifier is a unidirectional buffer which drives the current-share bus. The line which will interconnect all power modules paralleled for current sharing. Since the buffer amplifier will only source current, it insures that the module with the highest-output current will be the master and drive the bus with a low-impedance drive capability. All other buffer amplifiers will be inactive with each exhibiting a 10-k Ω load impedance to ground. The share bus terminal is protected against both shorts to ground and accidental voltages in excess of 50 V.

UC1907, UC2907, UC3907 LOAD SHARE CONTROLLER

SLUS165C – MARCH 1999 - REVISED JANUARY 2002

pin assignments

Adjust Amplifier: (Pins 13, 14, 15) This amplifier adjusts the individual module's reference voltage to maintain equal-current sharing. It is a transconductance type in order that its bandwidth may be limited and noise kept out of the reference-adjust circuitry, with a simple capacitor to ground. The function of this amplifier is to compare its own module-output current to the share-bus signal, which represents the highest output current. This will force an adjust command which is capable of increasing the reference voltage as seen by the voltage amplifier by as much as 100 mV. This number stems from the 17.5:1 internal resistor ratio between the adjust amplifier's clamped output and the reference, and represents a 5% total range of adjustment. This value should be adequate to compensate for unit-to-unit reference and external-resistor tolerances. The adjust amplifier has a built-in 50-mV offset on its inverting input which will force the unit acting as the master to have a low output, resulting in no change to the reference. While this 50-mV offset represents an error in current sharing, the gain of the current amplifier reduces it to only 2.5 mV across the current-sense resistor. It should also be noted that when the module is acting independently with no connection to the share bus node, or when the share bus node is shorted to ground, its reference voltage will be unchanged. Since only the circuit acting as a master will have a low output from the adjust amplifier, this signal is used to activate a flag output to identify the master, should some corrective action be needed.

Status Indicate: (Pin 16) This pin is an open-collector output intended to indicate the unit which is acting as the master. It achieves this by sensing when the adjust amp is in its low state and pulling the status-indicate pin low.

additional information

Please refer to additional application information.

1. By Mark Jordan, *UC3907 Load Share IC Simplifies Parallel Power Supply Design*, TI Literature Number SLUA147.
2. By Laszlo Balogh, *UC3902 Load Share Controller and its Performance in Distributed Power Systems*, TI Literature Number SLUA128.

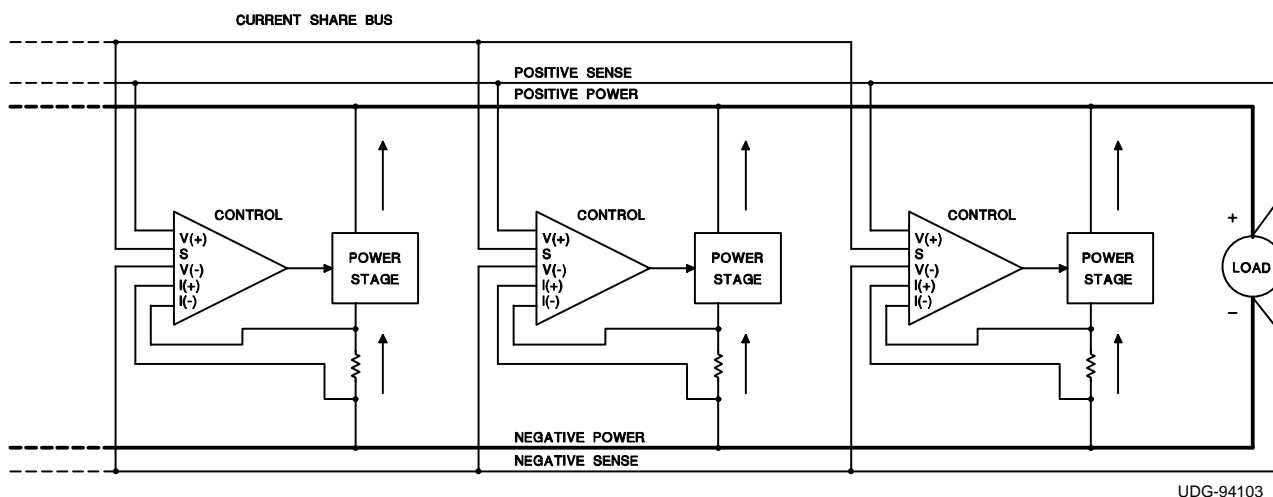
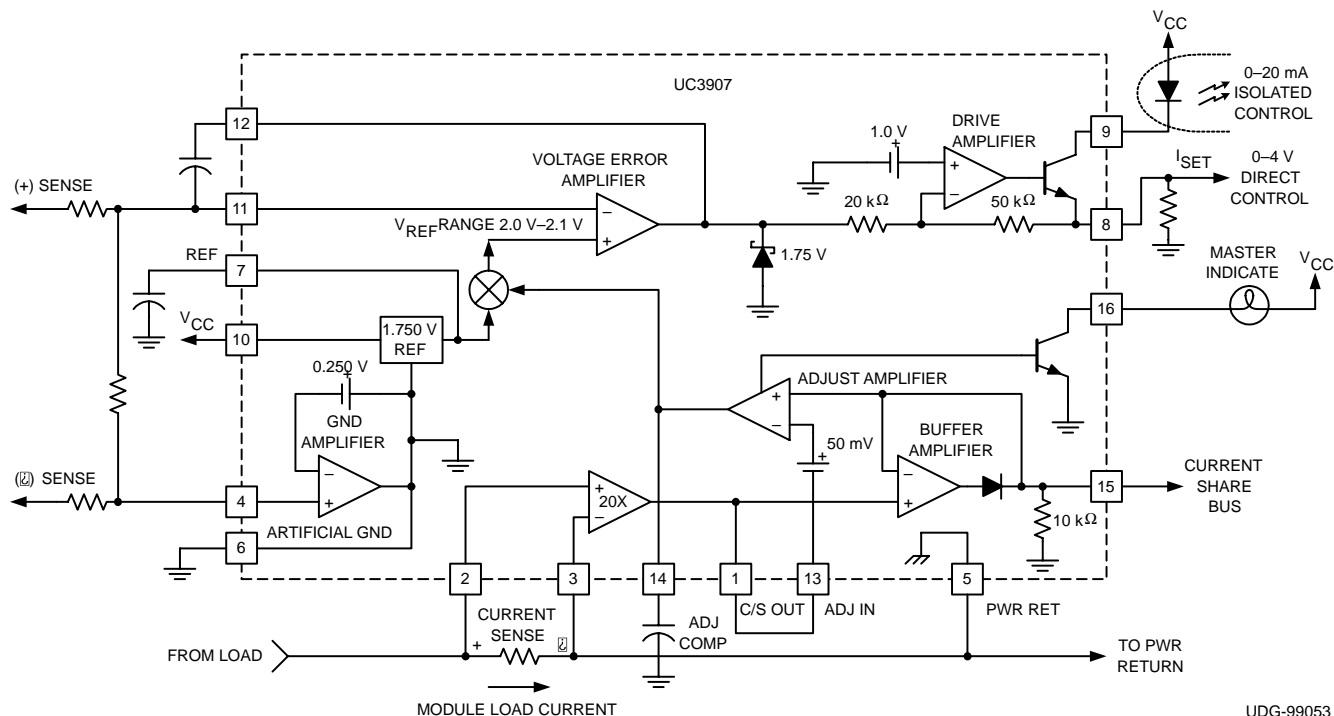

Figure 1. Load System Diagram

additional information (continued)



UDG-99053

Figure 2. Load System Connection Diagram

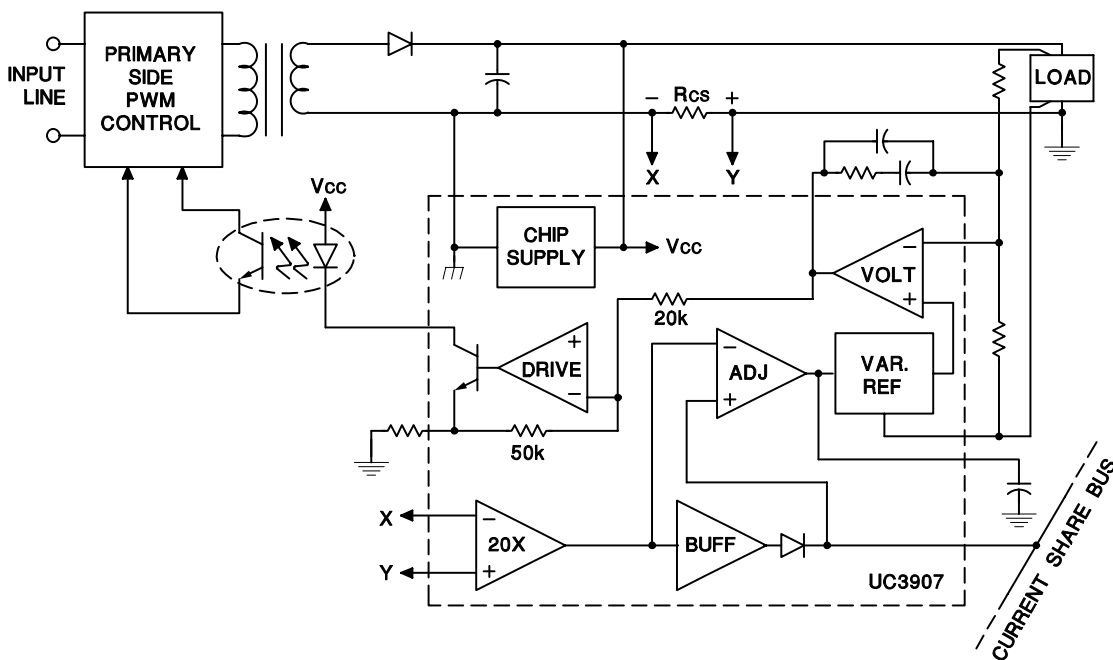

UDG-94105

Figure 3. UC3907 In a Load-Sharing Feedback Loop for an Off-Line Isolated Supply

IMPORTANT NOTICE

Texas Instruments Incorporated and its subsidiaries (TI) reserve the right to make corrections, modifications, enhancements, improvements, and other changes to its products and services at any time and to discontinue any product or service without notice. Customers should obtain the latest relevant information before placing orders and should verify that such information is current and complete. All products are sold subject to TI's terms and conditions of sale supplied at the time of order acknowledgment.

TI warrants performance of its hardware products to the specifications applicable at the time of sale in accordance with TI's standard warranty. Testing and other quality control techniques are used to the extent TI deems necessary to support this warranty. Except where mandated by government requirements, testing of all parameters of each product is not necessarily performed.

TI assumes no liability for applications assistance or customer product design. Customers are responsible for their products and applications using TI components. To minimize the risks associated with customer products and applications, customers should provide adequate design and operating safeguards.

TI does not warrant or represent that any license, either express or implied, is granted under any TI patent right, copyright, mask work right, or other TI intellectual property right relating to any combination, machine, or process in which TI products or services are used. Information published by TI regarding third-party products or services does not constitute a license from TI to use such products or services or a warranty or endorsement thereof. Use of such information may require a license from a third party under the patents or other intellectual property of the third party, or a license from TI under the patents or other intellectual property of TI.

Reproduction of information in TI data books or data sheets is permissible only if reproduction is without alteration and is accompanied by all associated warranties, conditions, limitations, and notices. Reproduction of this information with alteration is an unfair and deceptive business practice. TI is not responsible or liable for such altered documentation.

Resale of TI products or services with statements different from or beyond the parameters stated by TI for that product or service voids all express and any implied warranties for the associated TI product or service and is an unfair and deceptive business practice. TI is not responsible or liable for any such statements.

Mailing Address:

Texas Instruments
Post Office Box 655303
Dallas, Texas 75265