

● DISCRETE LEDs - Ø 5mm White

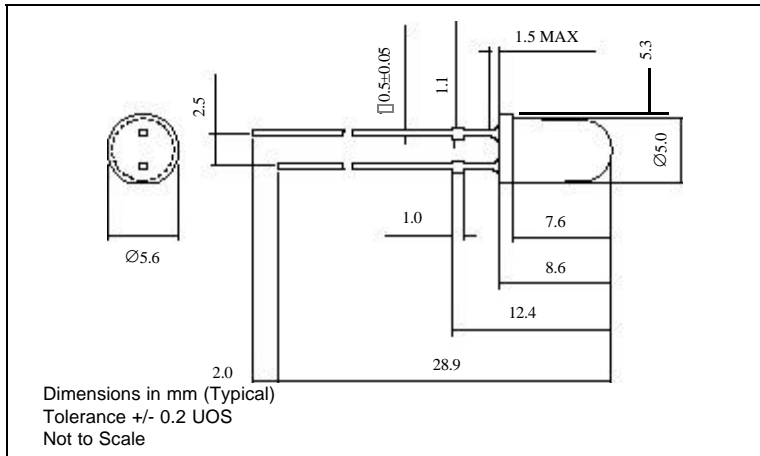

- High Intensity
- Also available as a 3mm device and in SMT format
- Solid state reliability
- Wider viewing angle version available

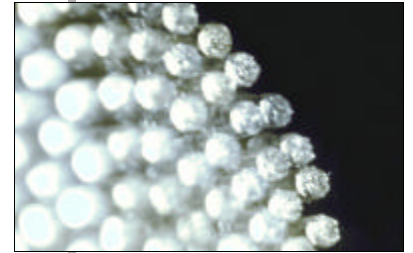

110147 SERIES

MLQ = 50

Ordering Information & Typical Technical Characteristics (Ta = 25°C)

Mean Time Between Failure = 100,000 Hours. \* Duty Cycle <= 1/10, Pulse Width <= 10msec

| PART NUMBER | COLOUR | TYP. FWD VOLTAGE<br>V <sub>f</sub> @ I <sub>opr</sub> | MAX FWD VOLTAGE<br>V <sub>f</sub> @ I <sub>opr</sub> | FORWARD CURRENT<br>I <sub>opr</sub> | MAX REV CURRENT<br>I <sub>r</sub> (V <sub>r</sub> =5V) | LUMINOUS INTENSITY<br>I <sub>v</sub> @I <sub>opr</sub> | CHROMATICITY COORDINATES | VIEWING ANGLE<br>2θ <sup>1/2</sup> |
|-------------|--------|---|--|-------------------------------------|--|--|--------------------------|------------------------------------|
|-------------|--------|---|--|-------------------------------------|--|--|--------------------------|------------------------------------|

OPTICAL / ELECTRICAL CHARACTERISTICS (T<sub>a</sub> = 25°C)

|        |             |     |     |    |    |      |             |     |
|--------|-------------|-----|-----|----|----|------|-------------|-----|
| 110147 | White       | 3.6 | 4.0 | 20 | 50 | 5600 | 0.31 / 0.32 | 20  |
| UNITS  | Water Clear | V   | V   | mA | µA | mcd  | x / y       | deg |

| PART NUMBER | COLOUR | FORWARD CURRENT<br>I <sub>opr</sub> max | PEAK FWD CURRENT<br>I <sub>fp</sub> * | REVERSE VOLTAGE<br>V <sub>r</sub> max | POWER DISSIPATION<br>P <sub>d</sub> max | OPERATING TEMP<br>T <sub>opr</sub> | STORAGE TEMP<br>T <sub>stg</sub> |
|-------------|--------|---|---------------------------------------|---------------------------------------|---|------------------------------------|----------------------------------|
|-------------|--------|---|---------------------------------------|---------------------------------------|---|------------------------------------|----------------------------------|

ABSOLUTE MAXIMUM RATINGS (T<sub>a</sub> = 25°C)

|        |             |    |     |     |     |            |             |
|--------|-------------|----|-----|-----|-----|------------|-------------|
| 110147 | White       | 30 | 100 | 5   | 120 | -30 to +85 | -40 to +100 |
| UNITS  | Water Clear | mA | mA  | Vdc | mW  | °C         | °C          |

PRECAUTIONS FOR HANDLING ELECTROSTATIC SENSITIVE LEDs

Static Electricity and Surge

Static electricity and surge will damage the LED and a high standard of care must be taken during handling. It is recommended that a wristband, conductive mat or anti-electrostatic glove is used when handling the LEDs. All devices, equipment (e.g. soldering iron points) and machinery must be properly grounded.

SAFETY PRECAUTIONS FOR HANDLING HIGH BRIGHTNESS LEDs

The light output of the Products may cause injuries to human eyes in circumstances where they are viewed directly with unshielded eyes for more than a few seconds.

Please refer to European Standard BSEN 100015-1 1992 for further information.

© Marl Optosource 2000

## ● WHITE DISCRETE LEDs - Technical Info.

**USAGE INFORMATION ON WHITE LEDS**

White LEDs are produced by combining blue LEDs and special phosphors and consequently the colour can vary slightly if different operating currents are used.

**Lead Forming**

During forming the leads should be bent at a point at least 3mm from the base of the epoxy. The base of the leadframe should not be used as a fulcrum during lead forming.

Lead forming should be carried out before soldering.

Do not apply any bending stress to the base of the lead as the stress may damage the LED.

When mounting the LED onto a PCB, the holes drilled on the PCB should be exactly aligned with the leads on the LED because if the LEDs are mounted with stress at the leads degradation of the epoxy resin could result.

**Soldering Conditions**

Do not solder the LEDs at a distance closer than 3mm from the base of the epoxy. Soldering the LED below the stand off is recommended.

Maximum allowable soldering conditions

**Soldering**

Soldering iron: 30W max

Temperature: 300° max

Soldering time: 3 seconds max

Position: No closer than 3mm  
from the base of the epoxy

**Solder Dipping**

Pre heat: 100°C max

Pre heat time: 60 seconds max

Solder bath temp: 260° C max

Dipping time: 5 seconds max

Dipping position: No lower than  
3mm from the epoxy

Do not apply any stress to the lead particularly when heated.

The LEDs must not be repositioned after soldering

After soldering the LED, the epoxy bulb should be protected from mechanical shock or vibration until the LED returns to room temperature.

Direct soldering onto a PC board should be avoided. Mechanical stress to the epoxy may be caused from warping of the PC board or from the cutting of the leadframes. When it is absolutely necessary, the LEDs may be mounted directly onto the board but the user must assume responsibility for any problems.

Direct soldering should only be done after testing has confirmed that no damage will occur.

LEDs should not be soldered directly onto double sided PCB's because the heat will deteriorate the epoxy resin.

When it is necessary to clamp the LED to prevent soldering failure it is important to minimise the mechanical stress on the LED.

Cut the LED leadframe at room temperature as cutting at high temperature can lead to failure of the LED.

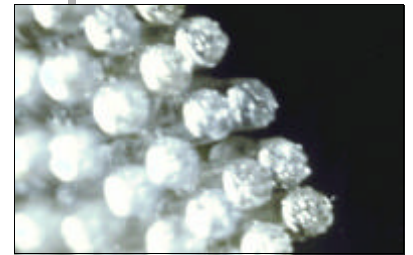

WHITE DISCRETES

MLQ = 50

● WHITE DISCRETE LEDs - Technical Info.

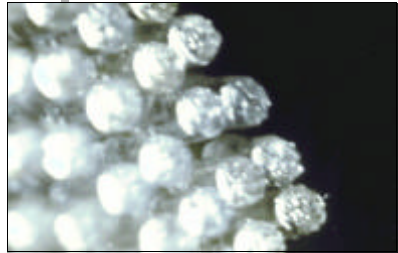

WHITE DISCRETES

MLQ = 50

**USAGE INFORMATION ON WHITE LEDS Ctd.**

**Static Electricity and Surges**

Both of the above will damage the LED. It is recommended to use a wrist band or antistatic glove when handling the LEDs. In addition all devices, equipment and machinery must be properly grounded.

Typical static electricity resistance figures are

Withstand voltage: 50V (C=200pf)  
 Standard test method: EIAJ ED-4701 (1992.2) C-111  
 Condition A

**Heat Generation**

This must be taken into account when using the LEDs as the temperature gets higher when the LEDs are densely mounted. It is necessary to design the circuit so that the operating temperatures are within the absolute maximum ratings of the device.

The operating current should be decided after consideration of the maximum ambient temperature when the LEDs are illuminated.

**Cleaning**

Avoid exposure to chemicals as they may discolour and damage the epoxy. When washing is required isopropyl alcohol should be used.

The influence of ultrasonic cleaning depends on how the LEDs are mounted and factors such as speed of oscillation. Before cleaning using this method tests should be carried out to ensure the LED will not be damaged.

**Other points**

Care must be taken so that reverse voltage will not exceed the absolute maximum rating when using LEDs with a matrix driver.

As the leads are silver plated they may become discoloured with Hydrogen Sulphide and other gaseous chemicals. Precautions must be taken to maintain a clean storing atmosphere.

The LED light output is strong enough to damage the human eye and precautions must be taken to prevent looking directly at the LED with unaided eyes for more than a few seconds.

WHITE DISCRETE LEDs - Technical Info.

COLOUR CO-ORDINATES AND RANKING INFORMATION

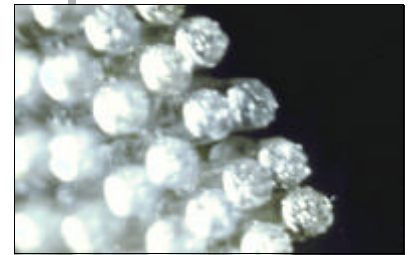

WHITE DISCRETES

MLQ = 50

Colour Ranks (IF=20MA, Ta=25°C)

| Rank a |       |       |       |       |
|--------|-------|-------|-------|-------|
| x      | 0.250 | 0.250 | 0.290 | 0.290 |
| y      | 0.205 | 0.250 | 0.305 | 0.260 |

| Rank b |       |       |       |       |
|--------|-------|-------|-------|-------|
| x      | 0.290 | 0.290 | 0.330 | 0.330 |
| y      | 0.260 | 0.305 | 0.365 | 0.320 |

| Rank c |       |       |       |       |
|--------|-------|-------|-------|-------|
| x      | 0.330 | 0.330 | 0.370 | 0.370 |
| y      | 0.320 | 0.365 | 0.420 | 0.375 |

Measurement Uncertainty of the Colour Coordinates: ±0.02

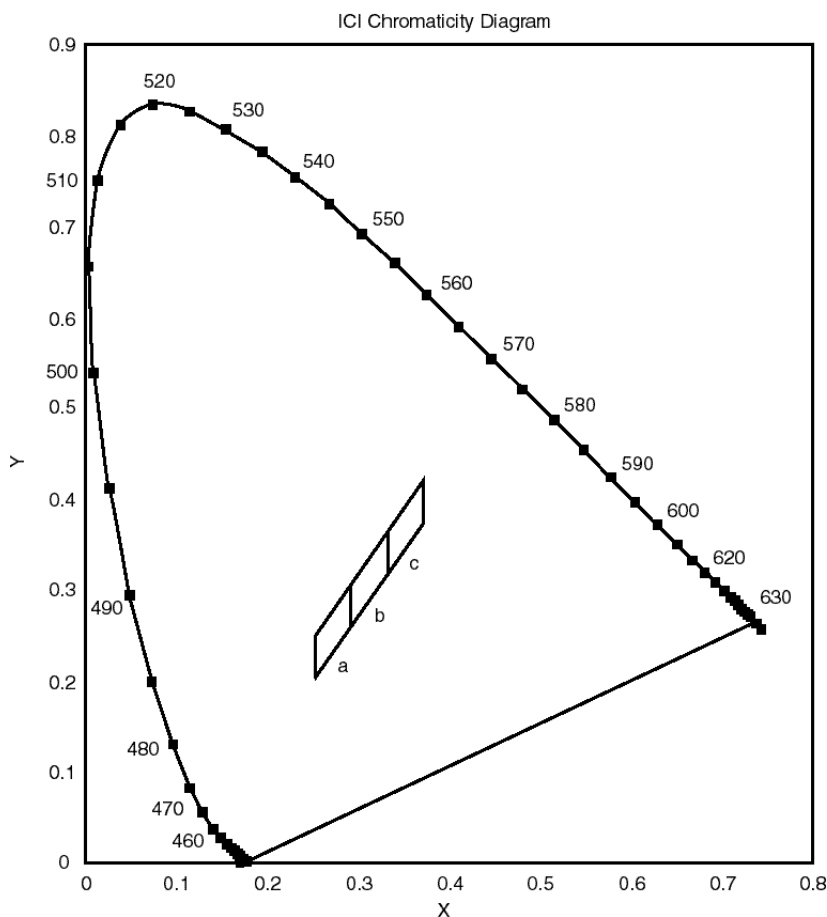

Rank B is supplied as standard.  
Other ranks (a and c) may be available upon request.

WHITE DISCRETE LEDs - Technical Info.

WHITE LED VIEWING ANGLES

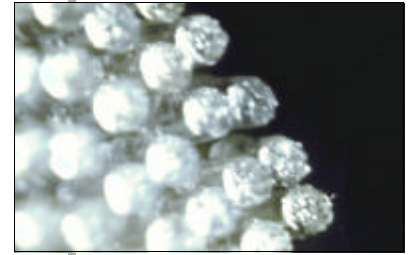

WHITE DISCRETES

MLQ = 50

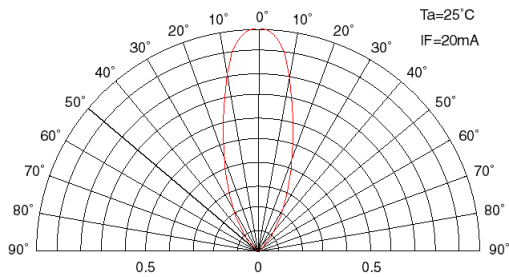

100059 01

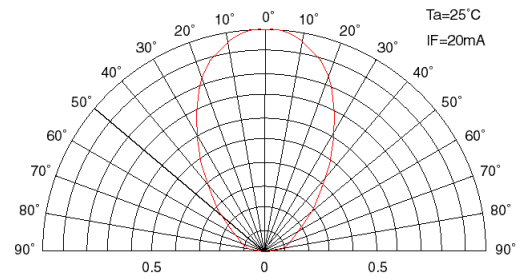

100053 01

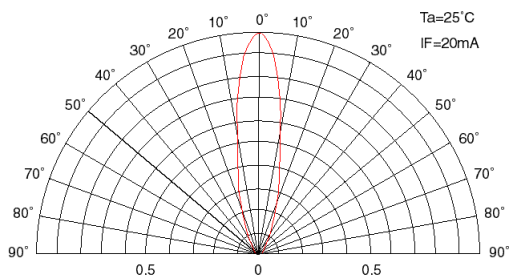

110147 01

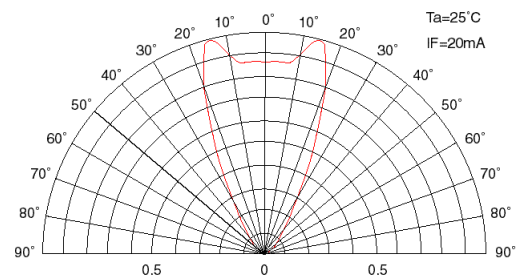

110140 01

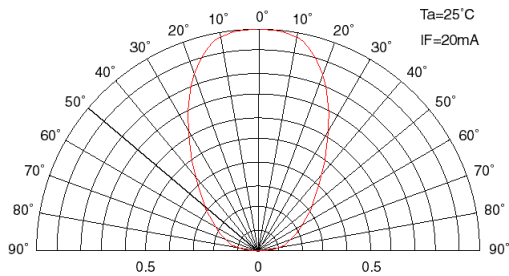

110155 01

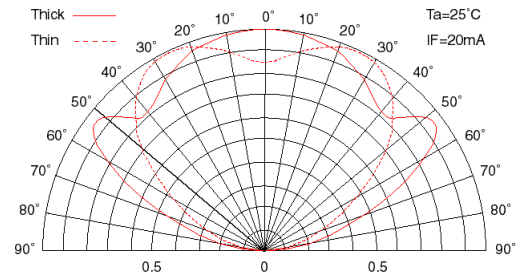

110163 01

WHITE DISCRETE LEDs - Technical Info.

WHITE LED TECHNICAL DATA

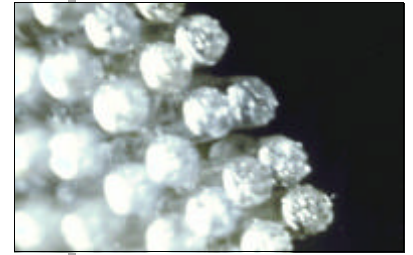

WHITE DISCRETES

MLQ = 50

